

**AUGUST 1999**

## **PROVINCIAL EXAMINATION**

**MINISTRY OF EDUCATION**

# **PHYSICS 12**

### **GENERAL INSTRUCTIONS**

1. Insert the stickers with your Student I.D. Number (PEN) in the allotted spaces above and on the **back** cover of this booklet. **Under no circumstance is your name or identification, other than your Student I.D. Number, to appear on this booklet.**
2. Ensure that in addition to this examination booklet, you have an **Examination Response Form**. Follow the directions on the front of the Response Form.
3. **Disqualification** from the examination will result if you bring books, paper, notes or unauthorized electronic devices into the examination room.
4. All multiple-choice answers must be entered on the Response Form using an **HB pencil**. Multiple-choice answers entered in this examination booklet will **not** be marked.
5. For each of the written-response questions, write your answer in the space provided in this booklet.
6. When instructed to open this booklet, **check the numbering of the pages** to ensure that they are numbered in sequence from page one to the last page, which is identified by

**END OF EXAMINATION**.

7. At the end of the examination, place your Response Form inside the front cover of this booklet and return the booklet and your Response Form to the supervisor.

**THIS PAGE INTENTIONALLY BLANK**

## PHYSICS 12 PROVINCIAL EXAMINATION

- |   | Value                   | Suggested Time     |
|---|-------------------------|--------------------|
| 1. This examination consists of <b>two</b> parts:         |                         |                    |
| PART A: 30 multiple-choice questions worth two marks each | 60                      | 60                 |
| PART B: 9 written-response questions                      | 60                      | 60                 |
|   | <b>Total: 120 marks</b> | <b>120 minutes</b> |
- Aside from an approved calculator, electronic devices, including dictionaries and pagers, are **not** permitted in the examination room.
  - The last **three** pages inside the back cover contain the **Table of Constants, Mathematical Equations, Formulae, and Rough Work for Multiple-Choice**. These pages may be detached for convenient reference prior to writing this examination.
  - Rough-work space has been incorporated into the space allowed for answering each written-response question. You may not need all of the space provided to answer each question.
  - A calculator is essential for the Physics 12 Provincial Examination.** The calculator must be a hand-held device designed primarily for mathematical computations involving logarithmic and trigonometric functions and may also include graphing functions. Computers, calculators with a QWERTY keyboard, and electronic writing pads will not be allowed. Students must not bring any external devices to support calculators such as manuals, printed or electronic cards, printers, memory expansion chips or cards, or external keyboards. Students may have more than one calculator available during the examination. Calculators may not be shared and must not have the ability to either transmit or receive electronic signals. In addition to an approved calculator, students will be allowed to use rulers, compasses, and protractors during the examination.
  - Final answers must include appropriate **units**.
    - Marks will not be deducted for answers expressed to **two** or **three** significant figures.
    - In this examination the zero in a number such as 30 shall be considered to be a significant zero.
  - You are expected to communicate your knowledge and understanding of physics principles in a clear and logical manner. Partial marks will be awarded for steps and assumptions leading to a solution. Full marks will **not** be awarded for providing **only** a final answer.

If you are unable to determine the value of a quantity required in order to proceed, you may assume a reasonable value and continue toward the solution. Such a solution, however, may not be eligible for full marks.
  - The time allotted for this examination is **two hours**.

**THIS PAGE INTENTIONALLY BLANK**

## PART A: MULTIPLE CHOICE

Value: 60 marks (2 marks per question)

Suggested Time: 60 minutes

**INSTRUCTIONS:** For each question, select the **best** answer and record your choice on the Response Form provided. Using an HB pencil, completely fill in the circle that has the letter corresponding to your answer.

1. Which of the following is true for projectile motion? (Ignore friction.)

	HORIZONTAL COMPONENT	VERTICAL COMPONENT
A.	constant velocity	constant velocity
B.	constant velocity	changing velocity
C.	changing velocity	constant velocity
D.	changing velocity	changing velocity

2. A ball is thrown vertically upward at 20 m/s from a height of 30 m above the ground. What is its speed on impact with the ground below?

- A. 14 m/s
- B. 24 m/s
- C. 31 m/s
- D. 44 m/s

3. A car travelling north at 20 m/s is later travelling west at 30 m/s. What is the direction of the change in velocity?

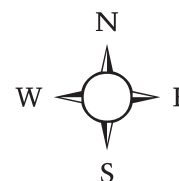
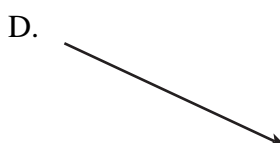
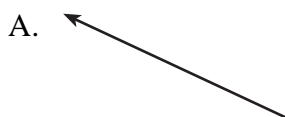

4. Which of the following graphs shows the relationship between acceleration and net force?

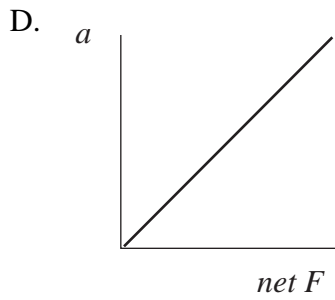
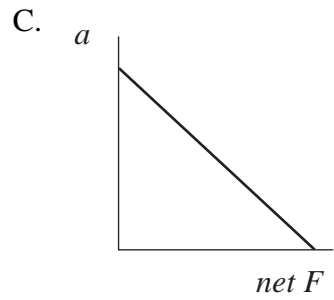
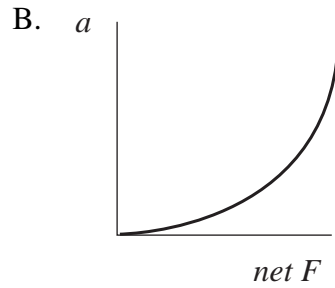
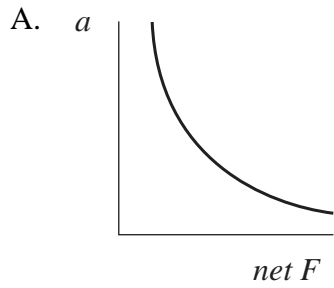

5. A 12 kg cart on a  $23^\circ$  frictionless incline is connected to a wall as shown.

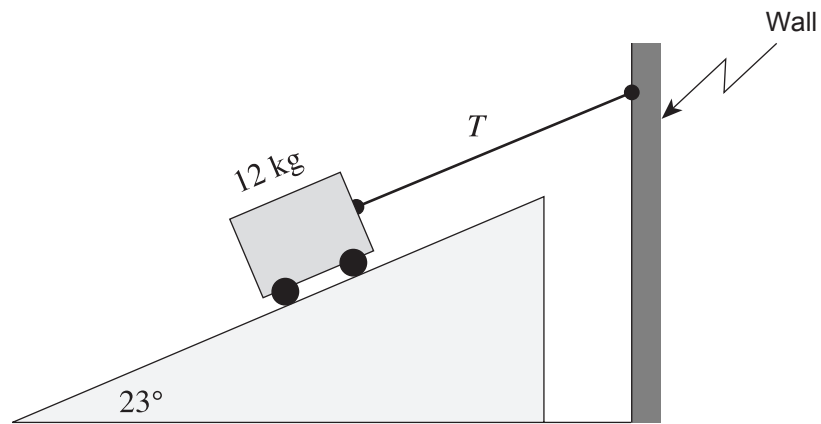

What is the tension  $T$  in the cord?

- A. 46 N
- B. 50 N
- C. 110 N
- D. 120 N

6. Is power a scalar or vector quantity, and which are the correct units for measuring it?

	TYPE OF QUANTITY	UNITS
A.	Scalar	J/m
B.	Scalar	J/s
C.	Vector	J/m
D.	Vector	J/s

7. A climber's gravitational potential energy increases from 14 000 J to 21 000 J while climbing a cliff. She expends 18 000 J of energy during this activity. What is the efficiency of this process?

- A. 3%
- B. 39%
- C. 61%
- D. 97%

8. A 40 000 kg rail car travelling at 2.5 m/s collides with and locks to a stationary 30 000 kg car. Determine the speed of the locked cars and state whether the collision is elastic or inelastic.

	SPEED OF LOCKED CARS	TYPE OF COLLISION
A.	1.4 m/s	Elastic
B.	1.4 m/s	Inelastic
C.	1.9 m/s	Elastic
D.	1.9 m/s	Inelastic

9. The unit for torque is

- A. J
- B. N · m
- C. N · s
- D. kg · m/s

10. An 85 kg object is suspended from a ceiling and attached to a wall.

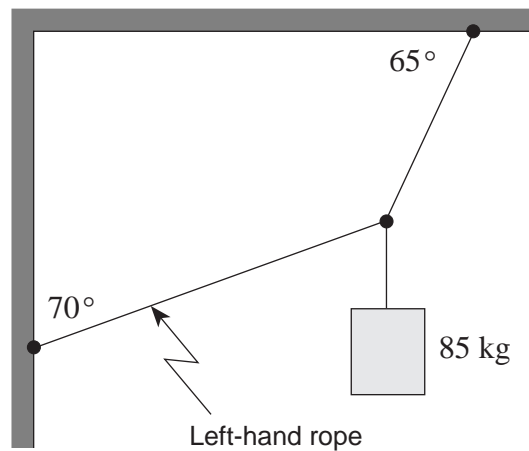

What is the tension in the left-hand rope?

- A. 280 N
- B. 350 N
- C. 500 N
- D. 1 100 N

11. A student stands on a uniform 25 kg beam. The scale on the right end reads 350 N.

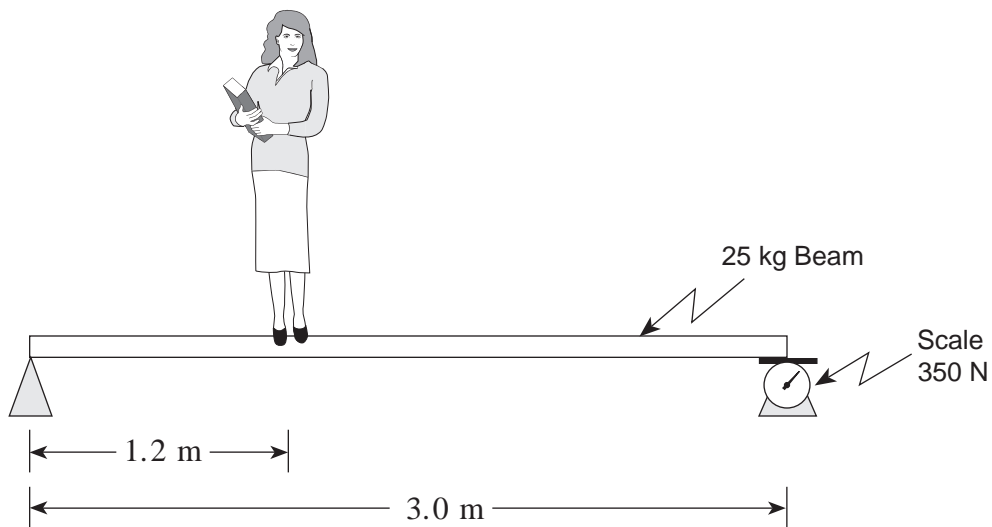

What is the mass of the student?

- A. 45 kg
- B. 54 kg
- C. 58 kg
- D. 89 kg



12. A small toy airplane suspended as shown below flies in a circular path.

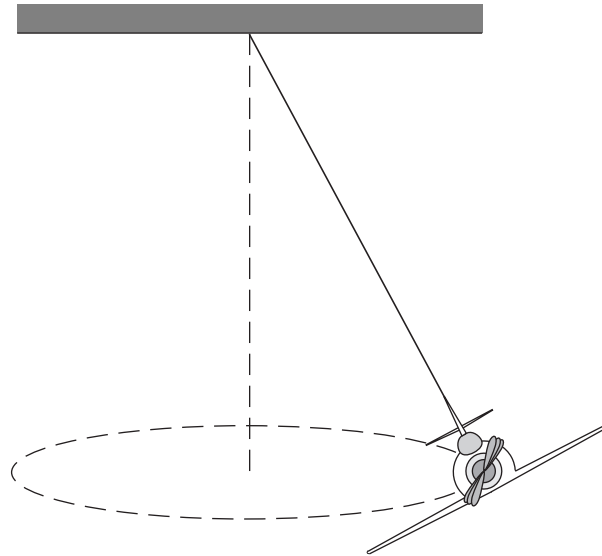

Which of the following free body diagrams best describes the forces acting on the airplane at the position shown?

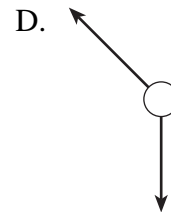
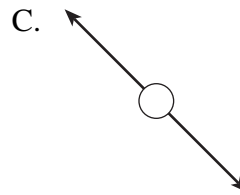
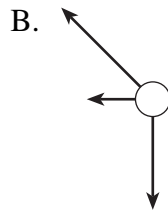
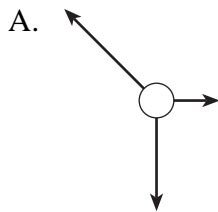

13. A 1.5 kg object is in uniform circular motion with a period of 3.0 s. If the radius of the path is 4.0 m, what is the centripetal force on the object?

- A. 18 N
- B. 26 N
- C. 41 N
- D. 59 N

14. An empty 12 kg seat on a swing-type ride at the fairgrounds has a kinetic energy of 480 J.

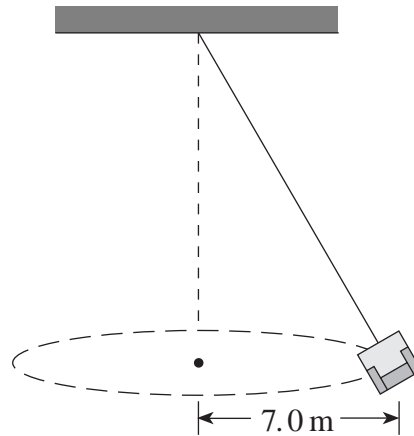

What is the centripetal force on the empty seat?

- A.  $1.2 \times 10^2$  N
  - B.  $1.4 \times 10^2$  N
  - C.  $8.2 \times 10^2$  N
  - D.  $5.8 \times 10^3$  N
15. A 75 kg person rides a Ferris wheel which is rotating uniformly. The centripetal force acting on the person is 45 N.

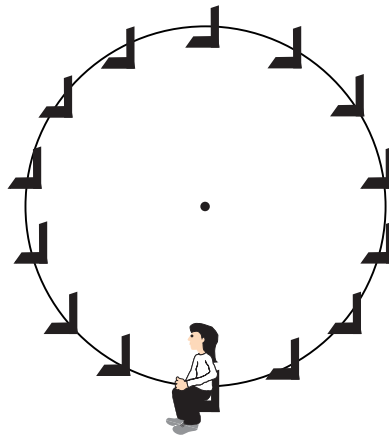

What force does the seat exert on the rider at the top and at the bottom of the ride?

	FORCE AT TOP	FORCE AT BOTTOM
A.	690 N	690 N
B.	690 N	780 N
C.	780 N	690 N
D.	780 N	780 N

16. Which of the following illustrates the work required to move an object in a gravitational field?

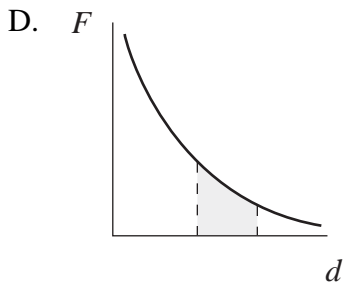
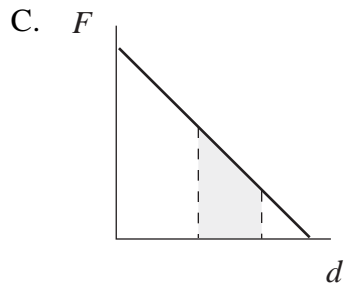
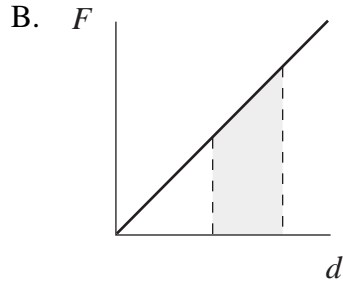
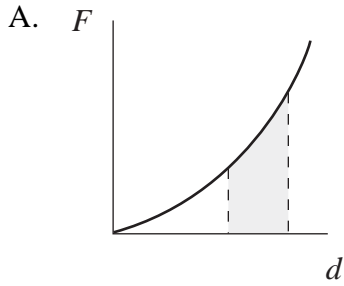

17. A 1 500 kg satellite orbits the earth at 2 500 m/s. What is the satellite's centripetal acceleration?

- A.  $0.098 \text{ m/s}^2$
- B.  $0.98 \text{ m/s}^2$
- C.  $9.8 \text{ m/s}^2$
- D.  $1.5 \times 10^2 \text{ m/s}^2$

18. Which diagram shows the electric field near a negative point charge?

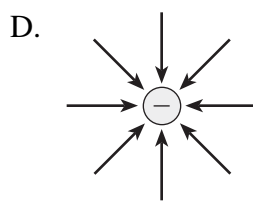
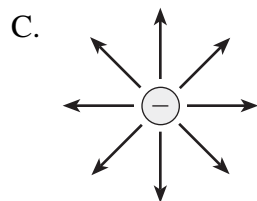
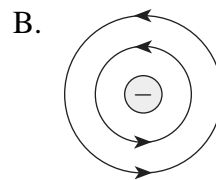
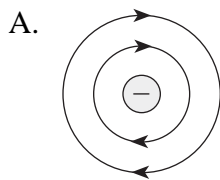

19. Which pair of values will cause the greatest deflection of an electron beam in a cathode ray tube?

	ACCELERATING VOLTAGE	DEFLECTION (PLATE) VOLTAGE
A.	400 V	20 V
B.	400 V	40 V
C.	800 V	20 V
D.	800 V	40 V

20. The magnitude of the net electric field at P in the diagram below is  $5.0 \times 10^3$  N/C.

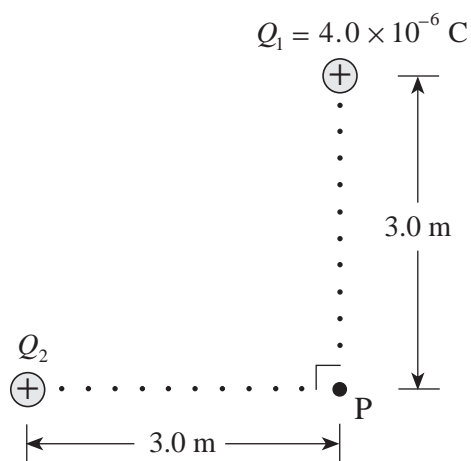

Find the magnitude of charge  $Q_2$ .

- A.  $1.0 \times 10^{-6} \text{ C}$   
 B.  $3.0 \times 10^{-6} \text{ C}$   
 C.  $6.4 \times 10^{-6} \text{ C}$   
 D.  $1.0 \times 10^{-5} \text{ C}$
21. Electricity is transmitted at high potential to
- A. operate heavy equipment.  
 B. maximize current in the transmission lines.  
 C. minimize the energy lost as heat in the transmission lines.  
 D. produce alternating currents because they always require high voltages.

22. Find the current flowing through resistor  $R_2$  in the circuit shown below.

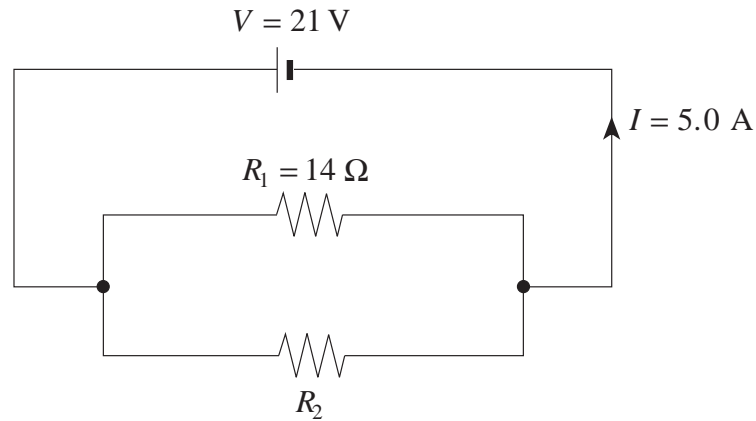

- A. 1.5 A
- B. 2.5 A
- C. 3.5 A
- D. 5.0 A

23. A cell has an internal resistance of  $0.50\ \Omega$ . It has a terminal voltage of  $1.4\text{ V}$  when connected to a  $5.0\ \Omega$  external resistance. What will its terminal voltage be if the  $5.0\ \Omega$  resistor is replaced by a  $10.0\ \Omega$  resistor?

- A. 0.70 V
- B. 1.4 V
- C. 1.5 V
- D. 2.8 V

24. An electric current flows through a solenoid as shown below.

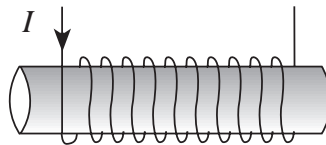

What is the direction of the magnetic field inside the solenoid?

- A.  $\xrightarrow{\vec{B}}$
- B.  $\xleftarrow{\vec{B}}$
- C.  $\uparrow \vec{B}$
- D.  $\downarrow \vec{B}$

**OVER**

25. A long conductor is placed in a  $0.65 \text{ T}$  magnetic field as shown below.

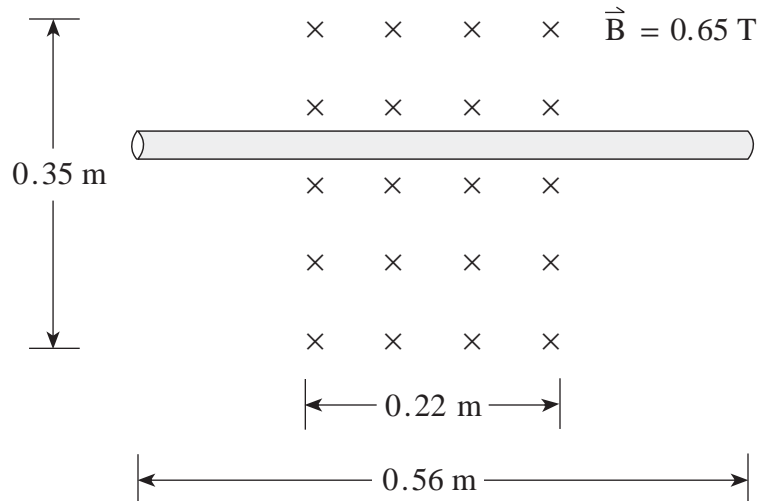

What are the magnitude and direction of the current that produces a  $1.6 \text{ N}$  force on the wire directed up the page?

	MAGNITUDE OF CURRENT	DIRECTION OF CURRENT
A.	4.4 A	Right
B.	4.4 A	Left
C.	11 A	Right
D.	11 A	Left

26. A proton has a speed of  $5.0 \times 10^6 \text{ m/s}$  while travelling perpendicular to a  $0.14 \text{ T}$  magnetic field. What is the magnetic force on the proton?

- A.  $1.6 \times 10^{-26} \text{ N}$
- B.  $8.4 \times 10^{-21} \text{ N}$
- C.  $2.2 \times 10^{-20} \text{ N}$
- D.  $1.1 \times 10^{-13} \text{ N}$

27. The flux through a circular coil with a radius of  $0.075 \text{ m}$  is  $0.013 \text{ Wb}$  when placed perpendicular to a magnetic field. What is the strength of the magnetic field?

- A.  $0 \text{ T}$
- B.  $0.17 \text{ T}$
- C.  $0.74 \text{ T}$
- D.  $2.3 \text{ T}$

28. The diagram below shows an aluminum ring and the current induced in it by the nearby magnet that is free to move along its central axis.

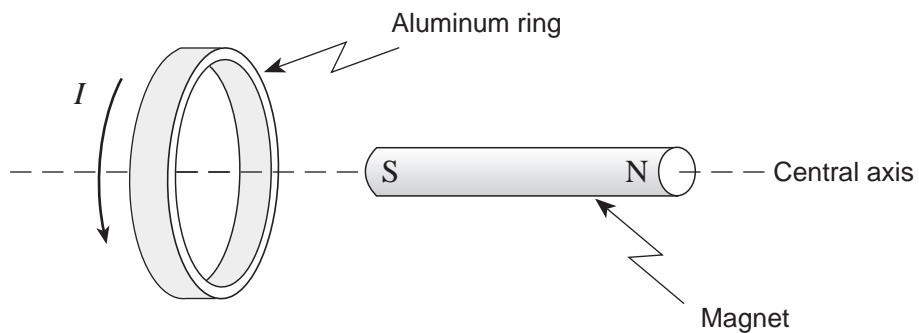

The magnet must be

- A. stationary.
  - B. moving to the left.
  - C. moving to the right.
  - D. spinning about its central axis.
29. A computer adapter contains a transformer that converts 120 V ac across its primary windings to 24 V ac across its secondary windings. The primary current is 1.2 A. What is the secondary current and what is the type of transformer?

	MAGNITUDE OF CURRENT	DIRECTION OF CURRENT
A.	0.24 A	Step-up
B.	0.24 A	Step-down
C.	6.0 A	Step-up
D.	6.0 A	Step-down

30. A loop of wire of area  $0.32 \text{ m}^2$  is placed in a  $0.75 \text{ T}$  magnetic field as shown. The magnetic field is changed to  $0.35 \text{ T}$  in the opposite direction in  $0.45 \text{ s}$ .

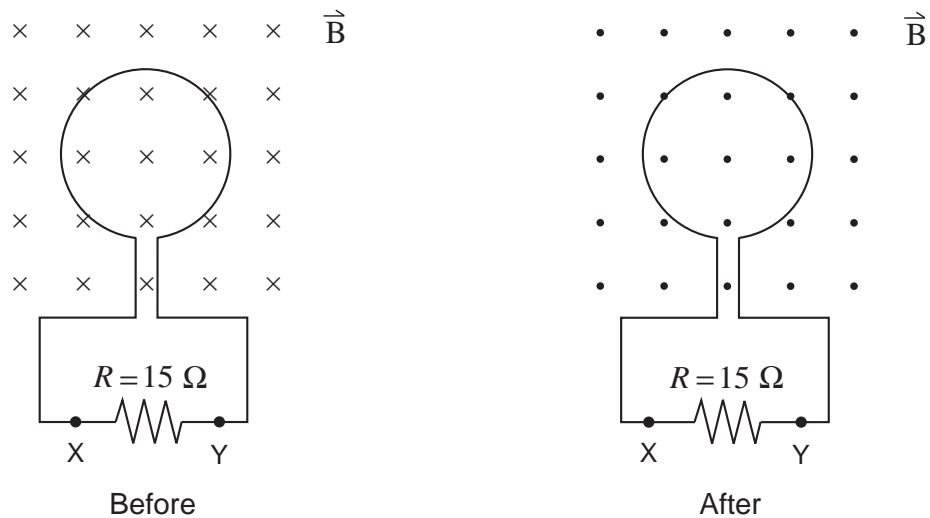

What are the magnitude and direction of the current through the  $15 \Omega$  resistor?

	MAGNITUDE OF CURRENT	DIRECTION OF CURRENT
A.	0.019 A	X to Y
B.	0.019 A	Y to X
C.	0.052 A	X to Y
D.	0.052 A	Y to X

**This is the end of the multiple-choice section.  
 Answer the remaining questions directly in this examination booklet.**



## PART B: WRITTEN RESPONSE

Value: 60 marks

Suggested Time: 60 minutes

### INSTRUCTIONS:

1. Rough-work space has been incorporated into the space allowed for answering each written-response question. You may not need all of the space provided to answer each question.
2.
  - a) Final answers must include appropriate **units**.
  - b) Marks will not be deducted for answers expressed to **two** or **three** significant figures.
  - c) In this examination the zero in a number such as 30 shall be considered to be a significant zero.
3. You are expected to communicate your knowledge and understanding of physics principles in a clear and logical manner. Partial marks will be awarded for steps and assumptions leading to a solution.
4. If you are unable to determine the value of a quantity required in order to proceed, you may assume a reasonable value and continue toward the solution. Such a solution, however, may not be eligible for full marks.
5. **Full marks will NOT be awarded for providing only a final answer.**

1. An 18 kg cart is connected to a 12 kg hanging block as shown. (Ignore friction.)

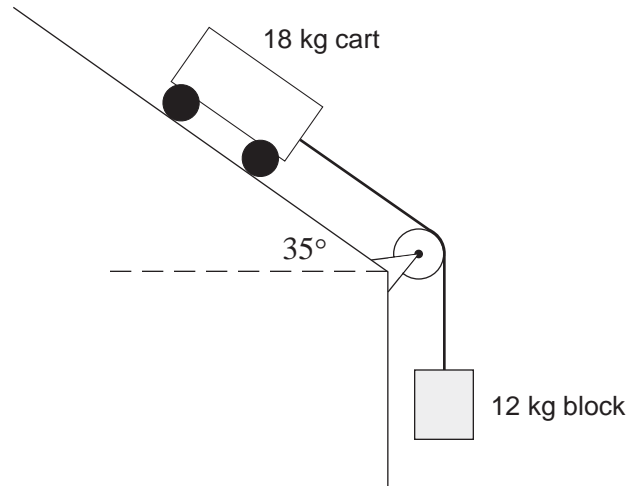

- a) Draw and label a free body diagram for the 18 kg cart.

**(2 marks)**

b) What is the magnitude of the acceleration of the cart?

**(5 marks)**

ANSWER:

b) acceleration: \_\_\_\_\_

2. A 0.25 kg cart travelling at 3.0 m/s collides with and sticks to an identical stationary cart on a level track. (Ignore friction.)

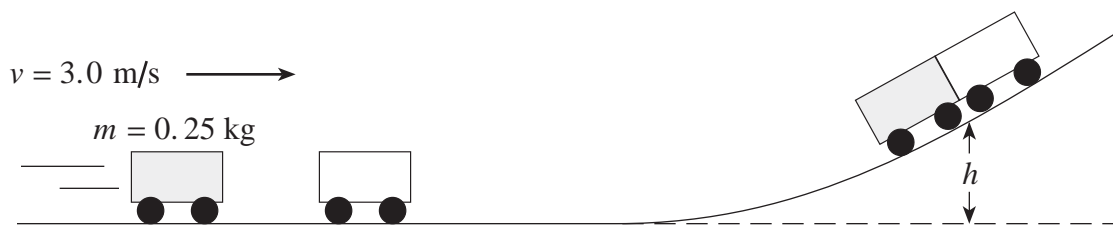

To what height  $h$  do the combined carts travel up the hill?

**(7 marks)**

ANSWER:

height: \_\_\_\_\_

**OVER**

3. A 6.0 m uniform beam of mass 32 kg is suspended horizontally by a hinged end and a cable. A 93 kg object is connected to one end of the beam.

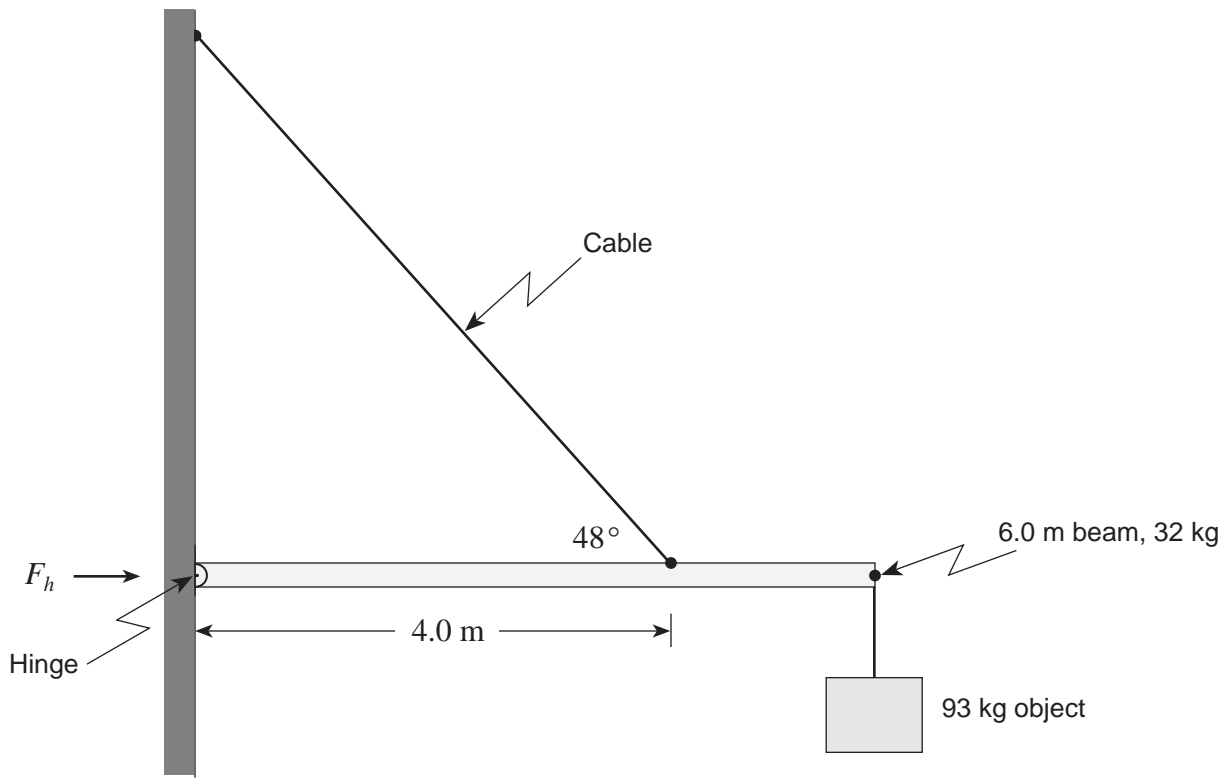

What is the magnitude of the horizontal force  $F_h$  that the hinge exerts on the beam? (7 marks)

ANSWER:

horizontal force: \_\_\_\_\_

4. A 1 500 kg satellite travels around the earth in a stable orbit with a radius of  $1.3 \times 10^7$  m.

a) What is the speed of the satellite in this orbit?

**(5 marks)**



b) The satellite is then moved to a new orbit with twice the radius of the first orbit. The speed in this orbit is

- the same as
- less than
- more than

the speed in the first orbit. (Check one response.)

**(1 mark)**

c) Using principles of physics, explain your answer to b).

**(3 marks)**

---

---

---

---

---

---

---

ANSWER:  a) speed: _____
--------------------------------

5. a) Find the electric potential at point A and at point B. (Note:  $1.0 \mu\text{C}$  is  $1.0 \times 10^{-6} \text{ C}$ )  
**(3 marks)**

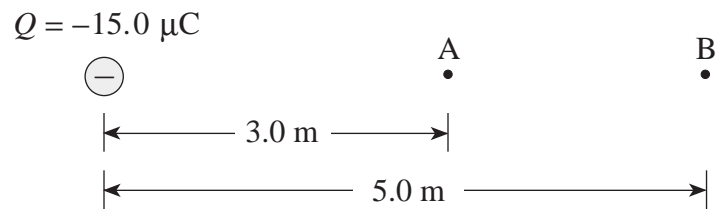

ANSWER:

a) potential at A: \_\_\_\_\_

potential at B: \_\_\_\_\_

b) What is the potential difference between A and B?

(1 mark)

ANSWER:

b) potential difference: \_\_\_\_\_

c) 0.036 J of work must be done to move a charge  $q$  from A to B. Find the magnitude and polarity of this charge. (3 marks)

$$Q = -15.0 \mu\text{C}$$

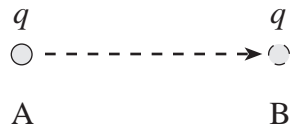

ANSWER:

c) charge: \_\_\_\_\_

polarity: \_\_\_\_\_

6. a) Find the value of resistor  $R_2$ .

(5 marks)

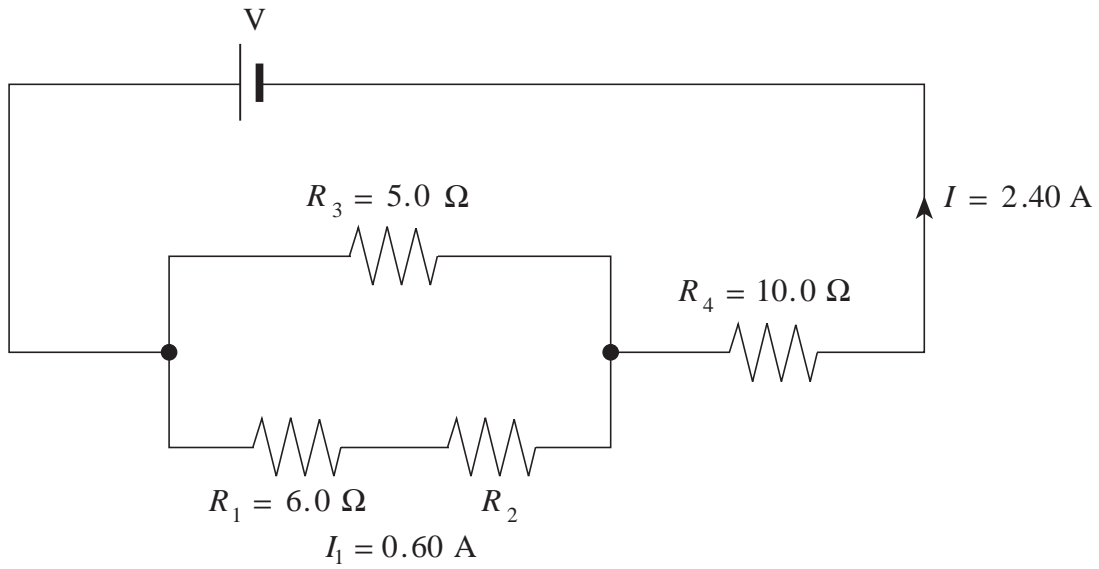

ANSWER:

a) resistor  $R_2$ : \_\_\_\_\_

b) Find the potential difference of the power supply V.

**(2 marks)**

ANSWER:

b) potential difference: \_\_\_\_\_

7. An automobile starter motor, connected to a  $12.0\text{ V}$  battery, produces a back emf of  $9.7\text{ V}$  when operating at normal speed. A malfunction prevents the starter motor from turning and the current increases to  $180\text{ A}$ . What current does the starter motor draw when operating normally? **(7 marks)**

ANSWER:

current: \_\_\_\_\_

**OVER**

8. An electric motor is connected to a 9.0 V power supply. The data table below shows how the back emf of the motor,  $V_{back}$ , varies with the current through the armature,  $I$ , as the mechanical load changes.

Back emf $V_{back}$ (V)	7.5	6.0	4.5	3.0	1.5	0
Current $I$ (A)	1.0	2.0	3.0	4.0	5.0	6.0

a) Plot this data on the graph below.

**(2 marks)**

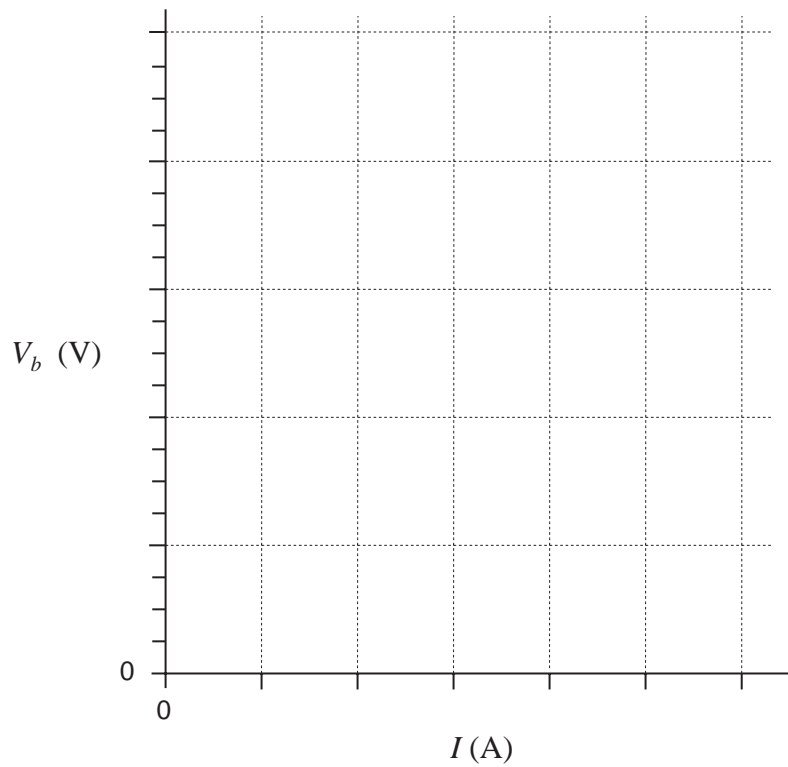



b) Determine the slope of this graph.

**(2 marks)**

c) What property of the motor does the slope of this graph represent?

**(1 mark)**

ANSWER:

b) slope: \_\_\_\_\_

9. A cyclist must do 1 000 J of work to speed up from 0 m/s to 5.0 m/s. The same cyclist must do 3 000 J of work to speed up from 5.0 m/s to 10.0 m/s. (In both instances friction has been ignored.) Using principles of physics, explain why more work must be done to speed up from 5.0 m/s to 10.0 m/s than from 0 m/s to 5.0 m/s. (Remember, friction plays no role in this problem.) **(4 marks)**

---

---

---

---

---

---

---

---

---

---

**END OF EXAMINATION**

## TABLE OF CONSTANTS

Gravitational constant .....	$G = 6.67 \times 10^{-11} \text{ N} \cdot \text{m}^2/\text{kg}^2$
Acceleration due to gravity at the surface of Earth (for the purposes of this examination) .....	$g = 9.80 \text{ m/s}^2$
<b>Earth</b>	
radius .....	$= 6.38 \times 10^6 \text{ m}$
radius of orbit about Sun .....	$= 1.50 \times 10^{11} \text{ m}$
period of rotation .....	$= 8.61 \times 10^4 \text{ s}$
period of revolution about Sun .....	$= 3.16 \times 10^7 \text{ s}$
mass .....	$= 5.98 \times 10^{24} \text{ kg}$
<b>Moon</b>	
radius .....	$= 1.74 \times 10^6 \text{ m}$
radius of orbit about Earth .....	$= 3.84 \times 10^8 \text{ m}$
period of rotation .....	$= 2.36 \times 10^6 \text{ s}$
period of revolution about Earth .....	$= 2.36 \times 10^6 \text{ s}$
mass .....	$= 7.35 \times 10^{22} \text{ kg}$
<b>Sun</b>	
mass .....	$= 1.98 \times 10^{30} \text{ kg}$
Constant in Coulomb's Law .....	$k = 9.00 \times 10^9 \text{ N} \cdot \text{m}^2/\text{C}^2$
Elementary charge .....	$e = 1.60 \times 10^{-19} \text{ C}$
Mass of electron .....	$m_e = 9.11 \times 10^{-31} \text{ kg}$
Mass of proton .....	$m_p = 1.67 \times 10^{-27} \text{ kg}$
Mass of neutron .....	$m_n = 1.68 \times 10^{-27} \text{ kg}$
Permeability of free space .....	$\mu_o = 4\pi \times 10^{-7} \text{ T} \cdot \text{m/A}$
Speed of light .....	$c = 3.00 \times 10^8 \text{ m/s}$

**You may detach this page for convenient reference.  
Exercise care when tearing along perforations.**

# MATHEMATICAL EQUATIONS

## For Right-angled Triangles:

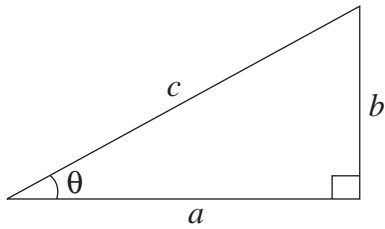

$$a^2 + b^2 = c^2$$

$$\sin \theta = \frac{b}{c} \quad \cos \theta = \frac{a}{c} \quad \tan \theta = \frac{b}{a}$$

$$\text{area} = \frac{1}{2} ab$$

## For All Triangles:

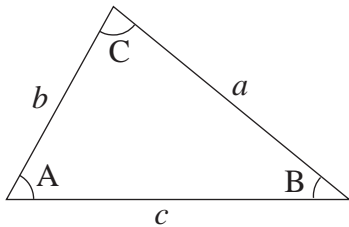

$$\text{area} = \frac{1}{2} \text{base} \times \text{height}$$

$$\sin 2A = 2 \sin A \cos A$$

$$\text{Sine Law: } \frac{\sin A}{a} = \frac{\sin B}{b} = \frac{\sin C}{c}$$

$$\text{Cosine Law: } c^2 = a^2 + b^2 - 2ab \cos C$$

## Circle:

$$\text{Circumference} = 2\pi r$$

$$\text{Area} = \pi r^2$$

## Sphere:

$$\text{Surface area} = 4\pi r^2$$

$$\text{Volume} = \frac{4}{3}\pi r^3$$

## Quadratic Equation:

$$\text{If } ax^2 + bx + c = 0, \text{ then } x = \frac{-b \pm \sqrt{b^2 - 4ac}}{2a}$$

**Vector Kinematics in Two Dimensions:**

$$v = v_0 + at \qquad \bar{v} = \frac{v + v_0}{2}$$

$$v^2 = v_0^2 + 2ad \qquad d = v_0t + \frac{1}{2}at^2$$

**Vector Dynamics:**

$$F_{\text{net}} = ma \qquad F_g = mg$$

$$F_{\text{fr}} = \mu F_N$$

**Work, Energy, and Power:**

$$W = Fd \qquad E_p = mgh$$

$$E_k = \frac{1}{2}mv^2 \qquad P = \frac{W}{t}$$

**Momentum:**

$$p = mv \qquad \Delta p = F\Delta t$$

**Equilibrium:**

$$\tau = Fd$$

**Circular Motion:**

$$a_c = \frac{v^2}{r} = \frac{4\pi^2 r}{T^2}$$

**Gravitation:**

$$F = G \frac{m_1 m_2}{r^2} \qquad E_p = -G \frac{m_1 m_2}{r}$$

**You may detach this page for convenient reference.  
Exercise care when tearing along perforations.**

### Electrostatics:

$$F = k \frac{Q_1 Q_2}{r^2} \quad E = \frac{F}{Q}$$

$$\Delta V = \frac{\Delta E_p}{Q} \quad E = \frac{\Delta V}{d}$$

$$E_p = k \frac{Q_1 Q_2}{r} \quad V = \frac{kQ}{r}$$

### Electric Circuits:

$$I = \frac{Q}{t} \quad V = IR$$

$$V_{\text{terminal}} = \mathcal{E} \pm Ir \quad P = IV$$

### Electromagnetism:

$$F = BIl \quad F = QvB$$

$$B = \mu_0 nI = \mu_0 \frac{N}{l} I \quad \mathcal{E} = Blv$$

$$\Phi = BA \quad \mathcal{E} = -N \frac{\Delta \Phi}{\Delta t}$$

$$V_{\text{back}} = \mathcal{E} - Ir$$

$$\frac{V_s}{V_p} = \frac{N_s}{N_p} = \frac{I_p}{I_s}$$

**ROUGH WORK FOR MULTIPLE-CHOICE**

**You may detach this page for convenient reference.  
Exercise care when tearing along perforations.**

## ROUGH WORK FOR MULTIPLE-CHOICE





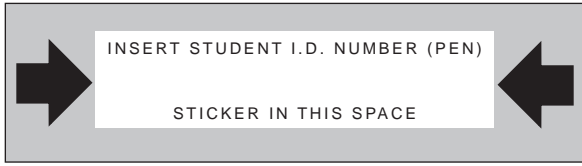

# **PHYSICS 12**

**August 1999**

Course Code = PH

FOR OFFICE USE ONLY

# PHYSICS 12

August 1999

Course Code = PH

Score for  
Question 1:

1.  $\frac{\quad}{(7)}$

Score for  
Question 8:

8.  $\frac{\quad}{(5)}$

Score for  
Question 2:

2.  $\frac{\quad}{(7)}$

Score for  
Question 9:

9.  $\frac{\quad}{(4)}$

Score for  
Question 3:

3.  $\frac{\quad}{(7)}$

Score for  
Question 4:

4.  $\frac{\quad}{(9)}$

Score for  
Question 5:

5.  $\frac{\quad}{(7)}$

Score for  
Question 6:

6.  $\frac{\quad}{(7)}$

Score for  
Question 7:

7.  $\frac{\quad}{(7)}$