

MINISTRY USE ONLY

MINISTRY USE ONLY

Place Personal Education Number (PEN) here.

Place Personal Education Number (PEN) here.



BRITISH  
COLUMBIA

© 2002 Ministry of Education

MINISTRY USE ONLY

Physics 12

JUNE 2002

Course Code = PH

### Student Instructions

1. Place the stickers with your Personal Education Number (PEN) in the allotted spaces above. **Under no circumstance is your name or identification, other than your Personal Education Number, to appear on this booklet.**
2. Ensure that in addition to this examination booklet, you have an **Examination Response Form**. Follow the directions on the front of the Response Form.
3. **Disqualification** from the examination will result if you bring books, paper, notes or unauthorized electronic devices into the examination room.
4. When instructed to open this booklet, **check the numbering of the pages** to ensure that they are numbered in sequence from page one to the last page, which is identified by **END OF EXAMINATION**.
5. At the end of the examination, place your Response Form inside the front cover of this booklet and return the booklet and your Response Form to the supervisor.

Question 1:

1.  .

(7)

Question 8:

8.  .

(5)

Question 2:

2.  .

(7)

Question 9:

9.  .

(4)

Question 3:

3.  .

(7)

Question 4:

4.  .

(9)

Question 5:

5.  .

(7)

Question 6:

6.  .

(7)

Question 7:

7.  .

(7)

# **PHYSICS 12**

**JUNE 2002**

COURSE CODE = PH

## GENERAL INSTRUCTIONS

1. Aside from an approved calculator, electronic devices, including dictionaries and pagers, are **not** permitted in the examination room.
2. All multiple-choice answers must be entered on the Response Form using an **HB pencil**. Multiple-choice answers entered in this examination booklet will **not** be marked.
3. For each of the written-response questions, write your answer in the space provided in this booklet. Rough-work space has been incorporated into the space allowed for answering each written-response question. You may not need all of the space provided to answer each question.
4. Ensure that you use language and content appropriate to the purpose and audience of this examination. Failure to comply may result in your paper being awarded a zero.
5. This examination is designed to be completed in **two hours**. *Students may, however, take up to 30 minutes of additional time to finish.*

## PHYSICS 12 PROVINCIAL EXAMINATION

- |   | Value         | Suggested Time     |
|---|---------------|--------------------|
| 1. This examination consists of <b>two</b> parts:         |               |                    |
| PART A: 30 multiple-choice questions worth two marks each | 60            | 60                 |
| PART B: 9 written-response questions                      | 60            | 60                 |
|   | <b>Total:</b> | <b>120 minutes</b> |
2. The last **three** pages inside the back cover contain the **Table of Constants, Mathematical Equations, Formulae, and Rough Work for Multiple-Choice**. These pages may be detached for convenient reference prior to writing this examination.
3. **A calculator is essential for the Physics 12 Provincial Examination.** The calculator must be a hand-held device designed primarily for mathematical computations involving logarithmic and trigonometric functions and may also include graphing functions. Computers, calculators with a QWERTY keyboard, and electronic writing pads will not be allowed. Students must not bring any external devices to support calculators such as manuals, printed or electronic cards, printers, memory expansion chips or cards, or external keyboards. Students may have more than one calculator available during the examination. Calculators may not be shared and must not have the ability to either transmit or receive electronic signals. In addition to an approved calculator, students will be allowed to use rulers, compasses, and protractors during the examination.
4. a) Final answers must include appropriate **units**.  
b) Marks will not be deducted for answers expressed to **two** or **three** significant figures.  
c) In this examination the zero in a number such as 30 shall be considered to be a significant zero.
5. You are expected to communicate your knowledge and understanding of physics principles in a clear and logical manner. Partial marks will be awarded for steps and assumptions leading to a solution. Full marks will **not** be awarded for providing **only** a final answer.

If you are unable to determine the value of a quantity required in order to proceed, you may assume a reasonable value and continue toward the solution. Such a solution, however, may not be eligible for full marks.

**THIS PAGE INTENTIONALLY BLANK**

**PART A: MULTIPLE CHOICE**

**Value: 60 marks (2 marks per question)**

**Suggested Time: 60 minutes**

**INSTRUCTIONS:** For each question, select the **best** answer and record your choice on the Response Form provided. Using an HB pencil, completely fill in the circle that has the letter corresponding to your answer.

1. A 1.5 kg block slides down the incline at a constant speed.

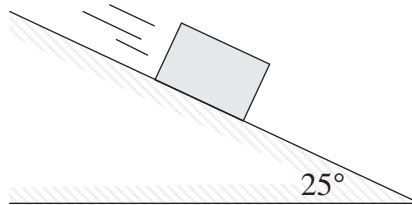

What is the net force on this block?

- A. 0 N
  - B. 6.2 N
  - C. 13 N
  - D. 15 N
2. A locomotive pulling a freight car accelerates at  $0.50 \text{ m/s}^2$  as shown in the diagram.

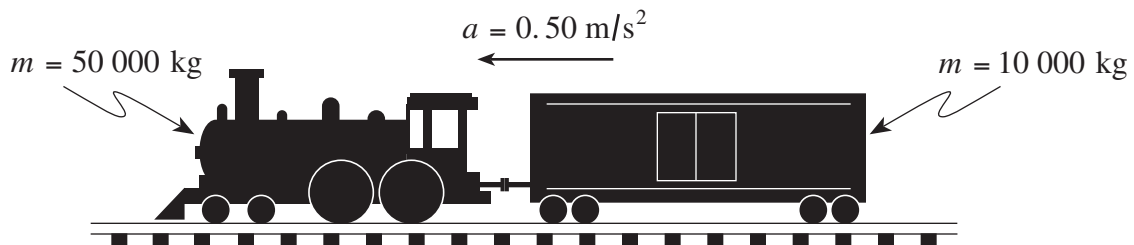

What is the tension in the coupling linking the locomotive and car? (Ignore friction.)

- A. 5 000 N
- B. 25 000 N
- C. 30 000 N
- D. 390 000 N

**OVER**

3. A 5.0 kg block is being pulled to the right by a 75 N force.

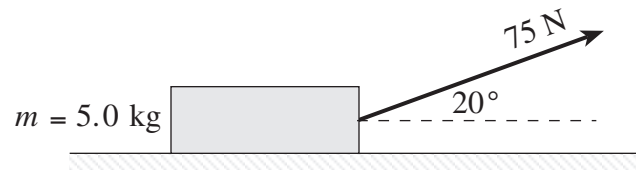

What is the normal force on this block?

- A. 23 N
  - B. 26 N
  - C. 49 N
  - D. 75 N
4. Two masses are connected by a string as shown in the diagram.

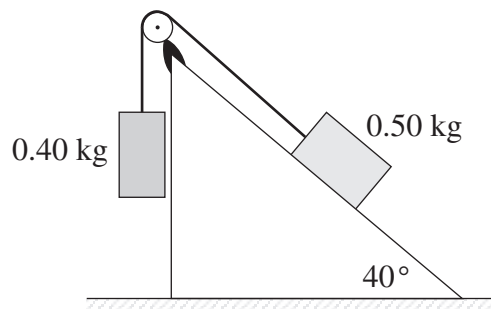

What is the magnitude of the acceleration of these masses? (Ignore friction.)

- A. 0.11 m/s<sup>2</sup>
  - B. 0.19 m/s<sup>2</sup>
  - C. 0.86 m/s<sup>2</sup>
  - D. 1.1 m/s<sup>2</sup>
5. The system of blocks shown in the diagram below is being accelerated to the right at 4.4 m/s<sup>2</sup>.

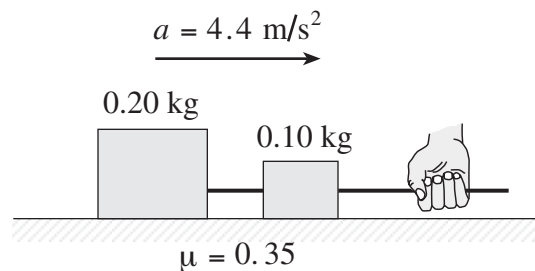

What pulling force is applied by the hand?

- A. 0.3 N
- B. 1.0 N
- C. 1.3 N
- D. 2.3 N



6. A 15 kg cement-filled bucket is raised to a vertical height of 5.0 m in 4.2 s by a motor drawing 373 W of power. What is the efficiency of this lifting system?
- A. 4.8%
  - B. 47%
  - C. 51%
  - D. 84%
7. An object moving due east at 15 m/s collides with a wall. As a result, the object moves due west at 15 m/s. Which of the following best describes the collision?
- A. elastic collision
  - B. inelastic collision
  - C. total momentum is increased
  - D. total momentum is decreased
8. A 5.0 kg model vehicle travelling at 14 m/s experiences a rocket boost of 85 N (in the direction of motion) for 20 s as shown on the graph.

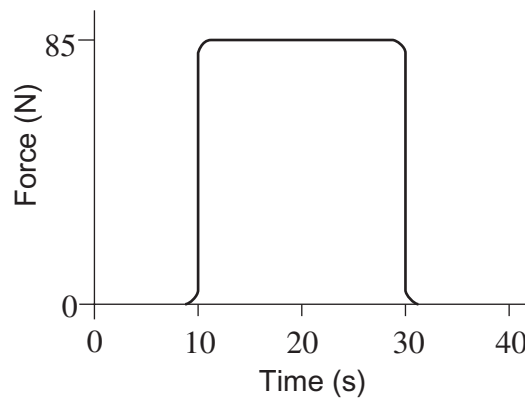

What is the resulting speed?

- A. 23 m/s
- B. 30 m/s
- C. 340 m/s
- D. 350 m/s

9. A 4.0 kg object moving due east at 15 m/s collides with and sticks onto a 12 kg object moving due south at 5.0 m/s. What is the resulting speed of the combined objects?
- A. 5.3 m/s  
 B. 10 m/s  
 C. 16 m/s  
 D. 20 m/s

10. A beam is suspended by cords from its ends as shown.

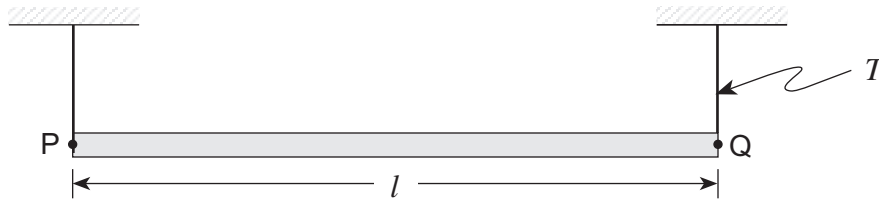

If the tension in the right hand cord is  $T$ , what is the sum of the torques about point P?

- A.  $0 \text{ N} \cdot \text{m}$   
 B.  $T \cdot l$   
 C.  $T \cdot l/2$   
 D.  $\frac{T}{l}$
11. Two forces act on an object as shown in the diagram below.

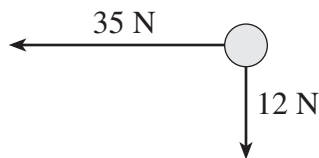

What are the magnitude and direction of a third force needed to keep the object in equilibrium?

	MAGNITUDE OF FORCE	DIRECTION OF FORCE
A.	37 N	$19^\circ$ below the horizontal
B.	37 N	$19^\circ$ above the horizontal
C.	47 N	$19^\circ$ below the horizontal
D.	47 N	$19^\circ$ above the horizontal

12. A 65 kg person is  $\frac{3}{4}$  of the way up the 4.0 m ladder as shown in the diagram below.

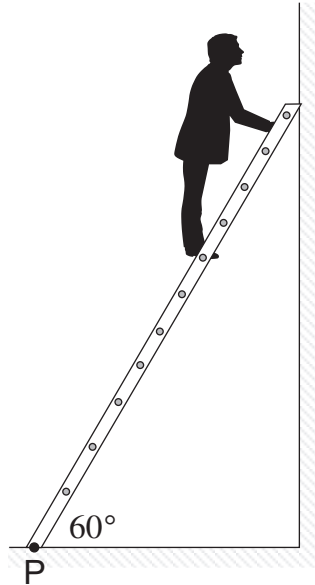

What are the magnitude and direction of the torque about the base of the ladder at P produced by the person?

	MAGNITUDE OF TORQUE	DIRECTION OF TORQUE
A.	$9.6 \times 10^2 \text{ N} \cdot \text{m}$	clockwise
B.	$9.6 \times 10^2 \text{ N} \cdot \text{m}$	counter-clockwise
C.	$1.9 \times 10^3 \text{ N} \cdot \text{m}$	clockwise
D.	$1.9 \times 10^3 \text{ N} \cdot \text{m}$	counter-clockwise

13. A car is moving at a constant speed around a circular curve. Which of the following best describes this situation?

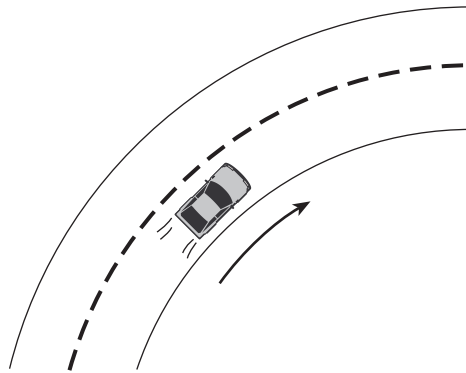

	VELOCITY OF CAR	ACCELERATION OF CAR	NET FORCE ON CAR
A.			
B.			
C.			
D.			

14. Which of the following best illustrates how the gravitational field strength of a body varies with distance  $r$  from the body's centre?

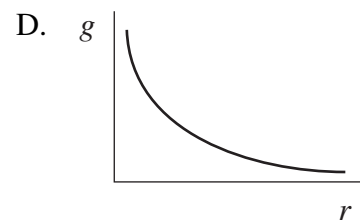
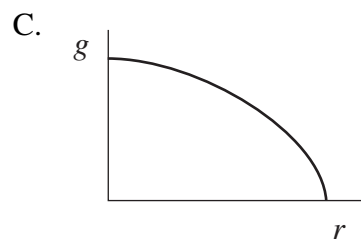
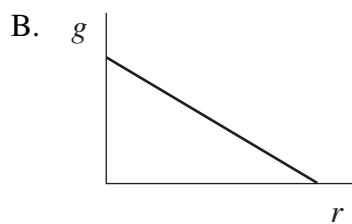
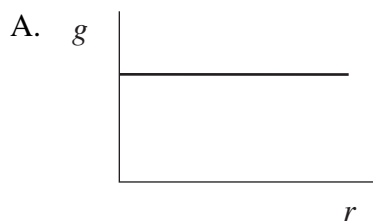

15. Which of the following graphs has a slope equal to the gravitational constant,  $G$ ?

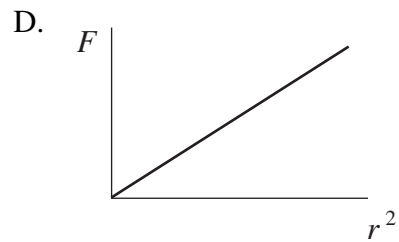
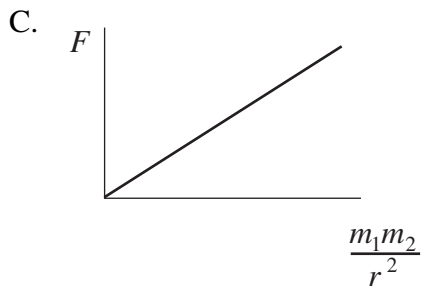
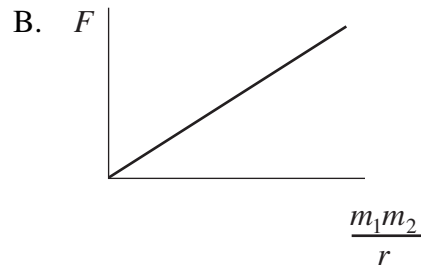
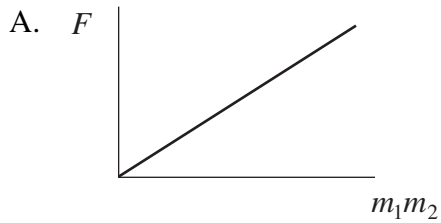

16. What is the gravitational force exerted on a 63 kg student by her 1400 kg car when their centres are 7.0 m apart?

- A.  $8.6 \times 10^{-11}$  N
- B.  $1.9 \times 10^{-9}$  N
- C.  $1.2 \times 10^{-7}$  N
- D.  $1.8 \times 10^3$  N

17. A satellite orbits the earth with a speed of  $7.3 \times 10^3$  m/s. What is the distance from the centre of the earth to this satellite?

- A.  $2.3 \times 10^5$  m
- B.  $3.8 \times 10^6$  m
- C.  $7.5 \times 10^6$  m
- D.  $1.3 \times 10^7$  m

18. At an altitude of  $1.3 \times 10^7$  m above the surface of the earth an incoming meteor of mass  $1.0 \times 10^6$  kg has a speed of  $6.5 \times 10^3$  m/s. What would be the speed just before impact with the surface of the earth? Ignore air resistance.
- A.  $9.1 \times 10^3$  m/s  
 B.  $1.0 \times 10^4$  m/s  
 C.  $1.1 \times 10^4$  m/s  
 D.  $1.7 \times 10^4$  m/s
19. Which of the following are correct units for electric potential?
- A. J/s  
 B. J/C  
 C. N/m  
 D. N/C
20. A proton beam is fired into a uniform electric field. The protons follow a parabolic path as shown.

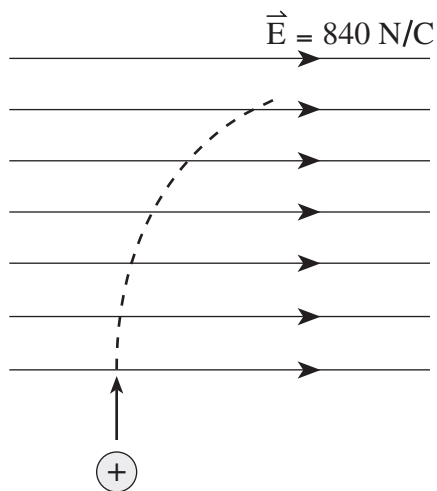

What is the acceleration of these protons?

- A.  $1.3 \times 10^{-16} \text{ m/s}^2$   
 B.  $8.0 \times 10^{10} \text{ m/s}^2$   
 C.  $1.5 \times 10^{14} \text{ m/s}^2$   
 D.  $5.0 \times 10^{29} \text{ m/s}^2$

21. A small 0.0021 kg plastic ball is suspended by a string in a uniform electric field as shown.

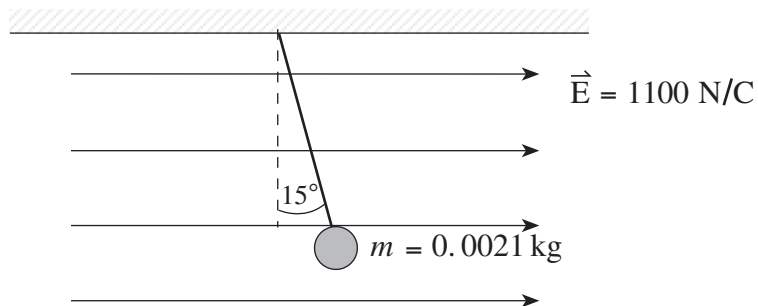

If the string makes an angle of  $15^\circ$  with the vertical, as indicated, what is the charge on the ball?

- A.  $4.8 \times 10^{-6} \text{ C}$
  - B.  $5.0 \times 10^{-6} \text{ C}$
  - C.  $1.9 \times 10^{-5} \text{ C}$
  - D.  $5.5 \times 10^{-3} \text{ C}$
22. Which of the following meter placements would allow you to measure the current through and electric potential difference across resistor,  $R$ ?

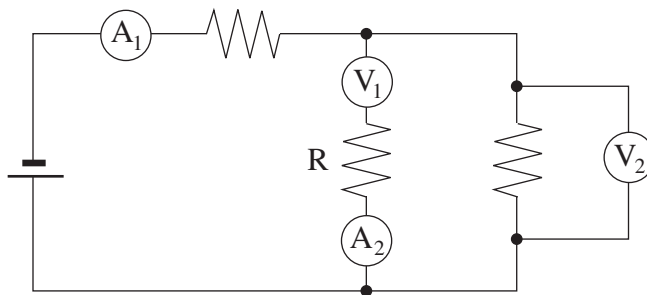

	AMMETER	VOLTMETER
A.	$A_1$	$V_1$
B.	$A_2$	$V_1$
C.	$A_1$	$V_2$
D.	$A_2$	$V_2$

23. What current flows through the  $4.00\ \Omega$  resistor in the following circuit?

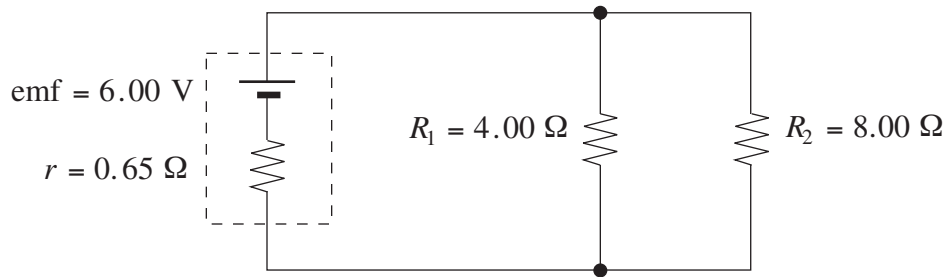

- A. 0.47 A
- B. 1.2 A
- C. 1.3 A
- D. 1.5 A

24. A circuit is made from two resistors and a light bulb as shown on the left. A short time later a copper wire is connected across points X and Y as shown on the right diagram.

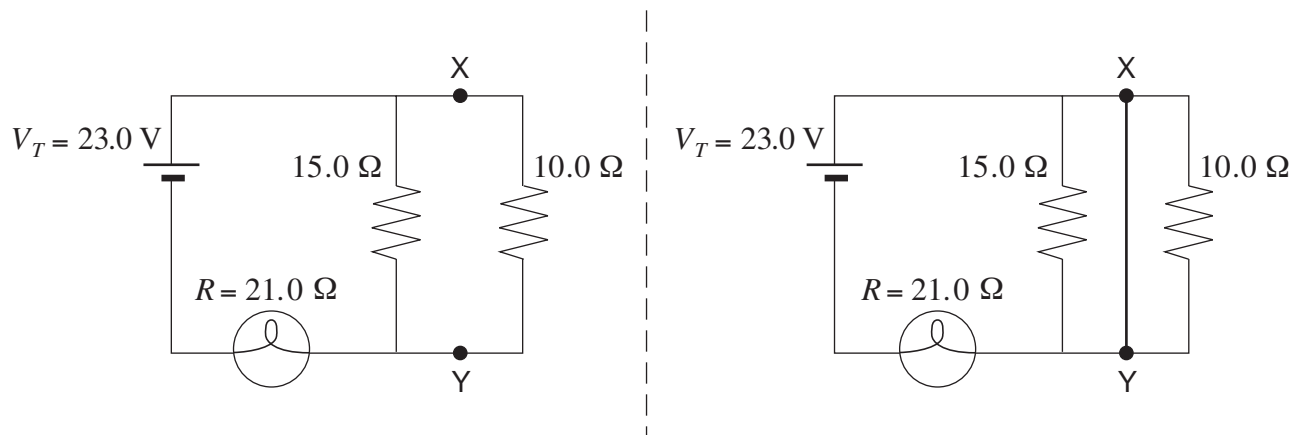

What is the current through the light bulb and what happens to the brightness of the bulb when the wire is connected?

	CURRENT	BRIGHTNESS OF BULB
A.	0.64 A	dimmer
B.	0.64 A	brighter
C.	1.10 A	dimmer
D.	1.10 A	brighter



25. Which of the following best describes the magnetic field inside a current-carrying solenoid as you move from A to B.

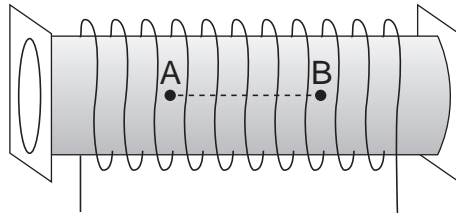

	DIRECTION	MAGNITUDE
A.	constant	constant
B.	constant	changing
C.	changing	constant
D.	changing	changing

26. A section of conductor is carrying a current due south, as shown below.

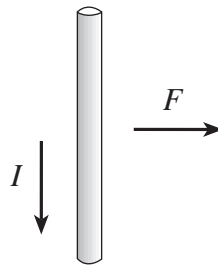

Due to the presence of a magnetic field, the conductor experiences a magnetic force to the right. What is the direction of the magnetic field?

- A. left
- B. right
- C. into the page
- D. out of the page

**OVER**

27. A charged mass is accelerated to various speeds and then passed through a perpendicular magnetic field. Which of the graphs below is the best representation of how the radius of its circular path through the magnetic field varies with speed?

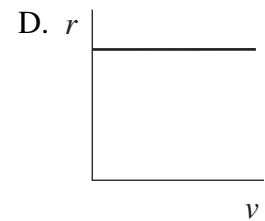
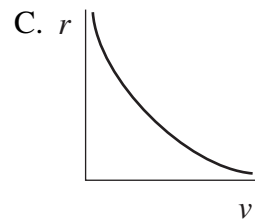
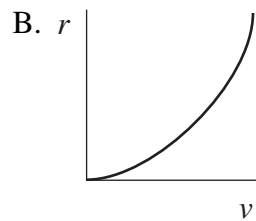
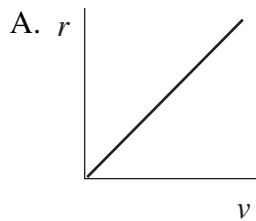

28. The single rectangular loop shown below is being pulled into the magnetic field at 2.0 m/s. Determine the emf developed in the loop.

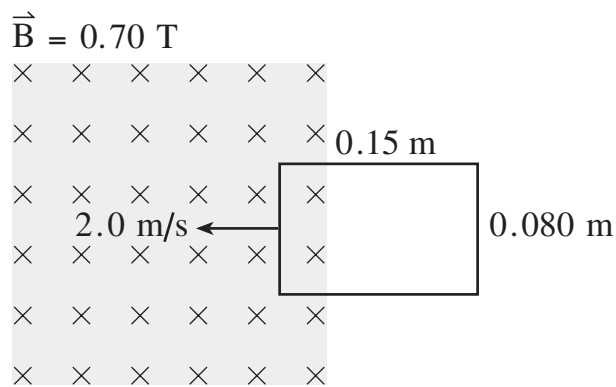

- A. 0.017 V  
 B. 0.11 V  
 C. 0.21 V  
 D. 0.64 V

29. You are using an electric drill to put a hole in a piece of wood when it hits a tough spot. The drill slows down and its motor heats up. Which of the choices below describes what has happened to the back emf and current?

	BACK EMF	CURRENT
A.	increased	increased
B.	decreased	decreased
C.	increased	decreased
D.	decreased	increased

30. Which of the following combinations in the primary coil of an ideal transformer causes an emf to be developed in the secondary coil?

	CURRENT	MAGNETIC FIELD
A.	constant	constant
B.	constant	changing
C.	changing	constant
D.	changing	changing

**This is the end of the multiple-choice section.  
Answer the remaining questions directly in this examination booklet.**

**THIS PAGE INTENTIONALLY BLANK**

## PART B: WRITTEN RESPONSE

Value: 60 marks

Suggested Time: 60 minutes

### INSTRUCTIONS:

1. Rough-work space has been incorporated into the space allowed for answering each written-response question. You may not need all of the space provided to answer each question.
2.
  - a) Final answers must include appropriate **units**.
  - b) Marks will not be deducted for answers expressed to **two** or **three** significant figures.
  - c) In this examination the zero in a number such as 30 shall be considered to be a significant zero.
3. You are expected to communicate your knowledge and understanding of physics principles in a clear and logical manner. Partial marks will be awarded for steps and assumptions leading to a solution.
4. If you are unable to determine the value of a quantity required in order to proceed, you may assume a reasonable value and continue toward the solution. Such a solution, however, may not be eligible for full marks.
5. **Full marks will NOT be awarded for providing only a final answer.**

1. A projectile is launched towards a wall as shown in the diagram below.

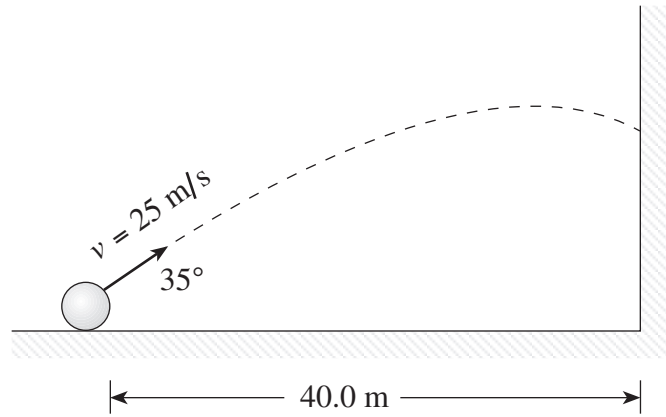

With what velocity (magnitude and direction) does the projectile hit the wall? **(7 marks)**

ANSWER:

magnitude of velocity: \_\_\_\_\_

direction of velocity: \_\_\_\_\_

**OVER**

2. A 0.50 kg ball starting from position A which is 7.5 m above the ground, is projected down an incline as shown. Friction produces 10.7 J of heat energy.

The ball leaves the incline at position B travelling straight upward and reaches a height of 13.0 m above the floor before falling back down.

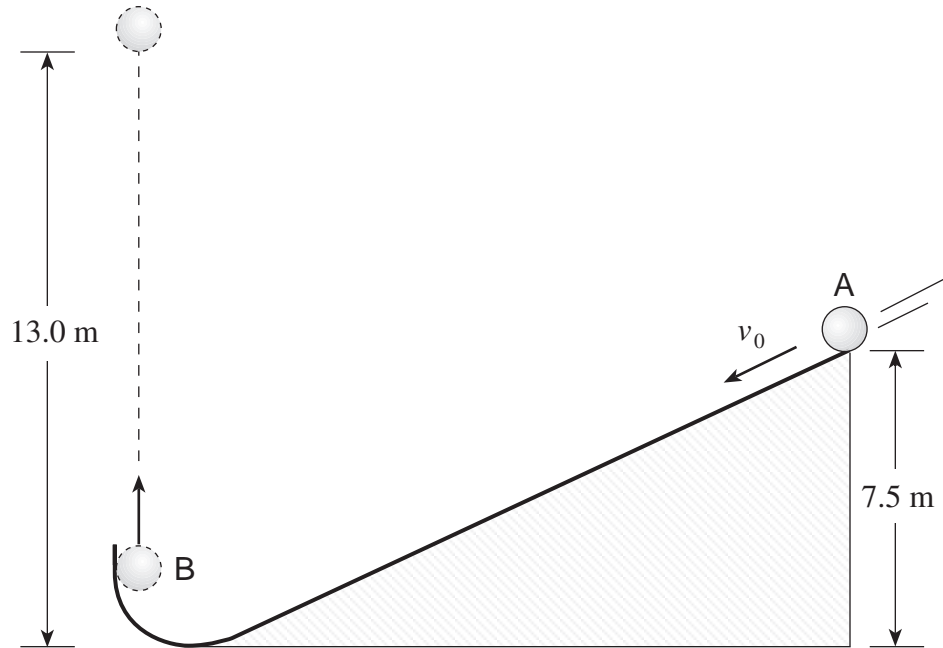

What was the initial speed,  $v_0$ , at position A? Ignore air resistance.

**(7 marks)**



ANSWER:

initial speed: \_\_\_\_\_

**OVER**

3. The crane assembly shown in the diagram below consists of a uniform 4.0 m long 65 kg strut and a restraining cable.

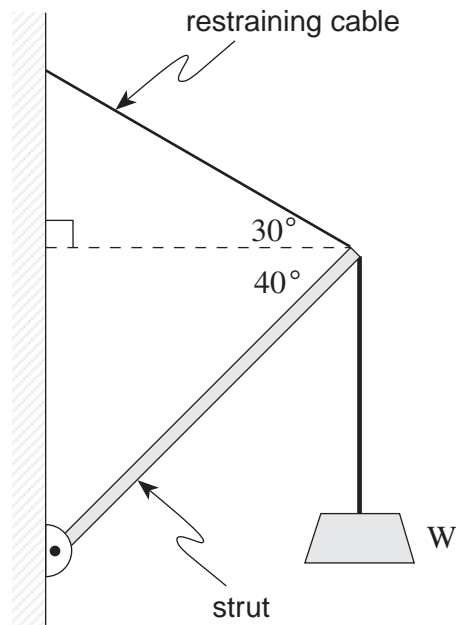

What is the maximum weight  $W$  that can be supported by this crane if the maximum tension that the restraining cable can withstand is 2400 N? The vertical rope is strong enough to support any required load. **(7 marks)**

ANSWER:

maximum weight: \_\_\_\_\_

**OVER**

4. A space station of radius 90 m is rotating to simulate a gravitational field.

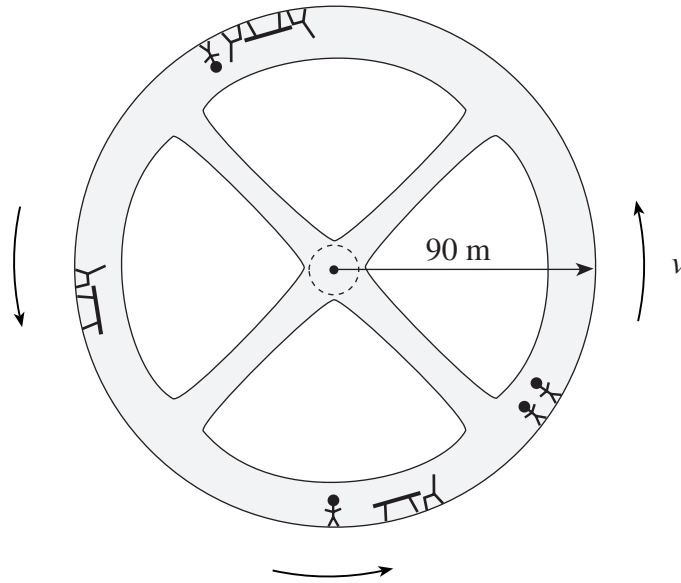

- a) What is the period of the space station's rotation so that a 70 kg astronaut will experience a normal force by the outer wall equal to 60% of his weight on the surface of the earth? **(5 marks)**

ANSWER:

a) period of rotation: \_\_\_\_\_

- b) What would be the effect experienced by the astronaut if the space station rotated faster so that the period of rotation was decreased? Explain your predicted effect. **(4 marks)**

---

---

---

---

---

---

---

5. What is the electric potential difference between points P and R due to the fixed point charge  $Q$ ? (7 marks)

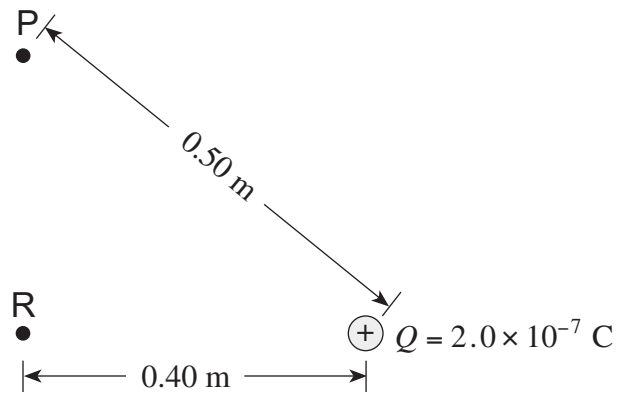

ANSWER:  
potential difference: \_\_\_\_\_

**OVER**

6. Each of the two cells shown is connected to an external  $6.00 \Omega$  resistor.

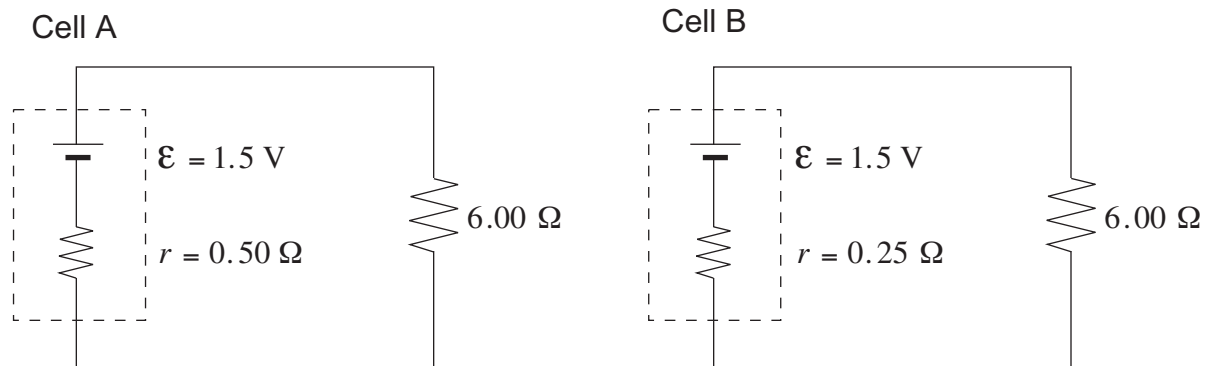

With supporting calculations, state which cell delivers the greater power to the  $6.00 \Omega$  resistor.  
**(7 marks)**



ANSWER:

cell delivering the greater power: \_\_\_\_\_

**OVER**

7. A coil of wire containing 50 loops is lying on a flat surface in a 0.60 T magnetic field pointing directly into the surface.

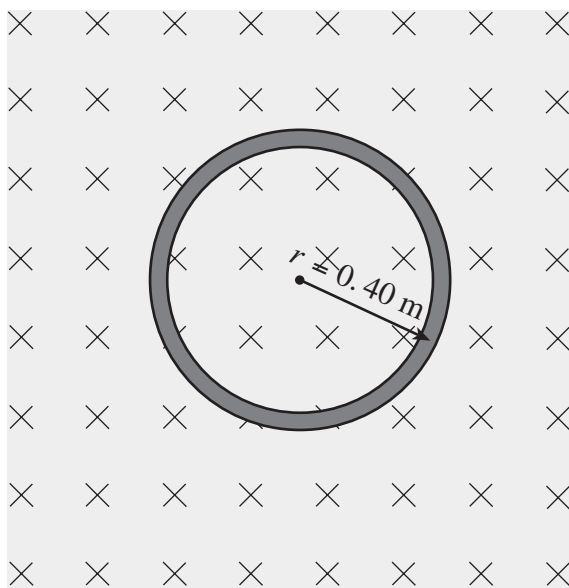

The magnetic field then changes to a value of 0.10 T in the opposite direction in 2.10 s. What is the average emf induced in the coil during the time that the magnetic field was changing? **(7 marks)**

ANSWER:

average emf: \_\_\_\_\_

**OVER**

8. As a formula one race car accelerates uniformly from rest, its momentum is recorded at regular time intervals. This data is shown below.

Time (s)	$p(\text{kg} \cdot \text{m/s})$
0.50	3 800
1.0	8 300
1.5	11 500
2.0	16 800
2.5	19 000

- a) Plot the data on the graph below and draw the best fit straight line.

**(2 marks)**

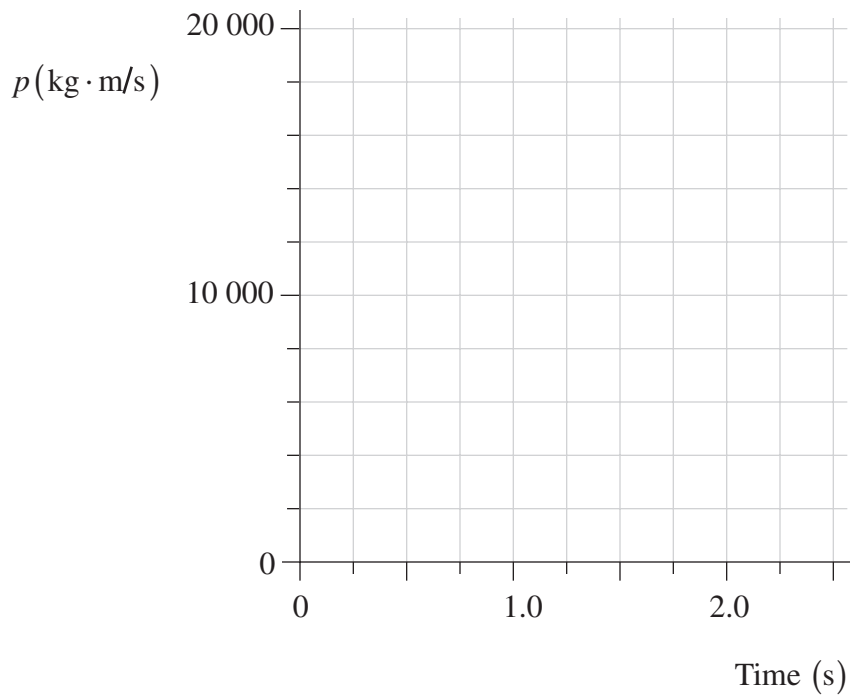

b) Determine the slope of the line (include units).

**(1 mark)**

ANSWER:

b) slope: \_\_\_\_\_

c) What does the slope of this line represent?

**(2 marks)**

ANSWER:

c) slope represents: \_\_\_\_\_

**OVER**

9. A steel rod passes through a region where a magnetic field exists.

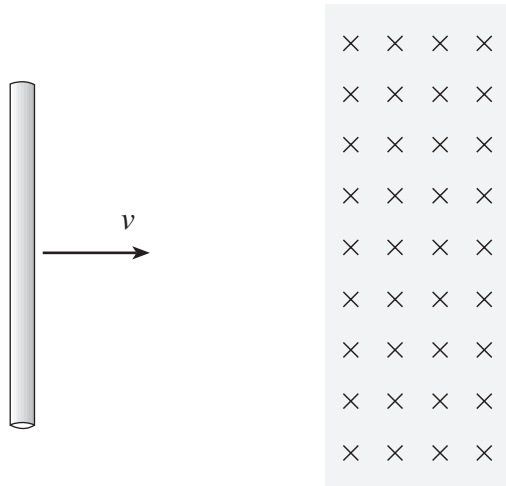

The rod slows as it passes through the magnetic field. Using principles of physics, explain why this happens. **(4 marks)**

---

---

---

---

---

---

---

---

---

---

**END OF EXAMINATION**

## TABLE OF CONSTANTS

Gravitational constant .....	$G = 6.67 \times 10^{-11} \text{ N} \cdot \text{m}^2/\text{kg}^2$
Acceleration due to gravity at the surface of Earth (for the purposes of this examination) .....	$g = 9.80 \text{ m/s}^2$
<b>Earth</b>	
radius .....	$= 6.38 \times 10^6 \text{ m}$
radius of orbit about Sun .....	$= 1.50 \times 10^{11} \text{ m}$
period of rotation .....	$= 8.61 \times 10^4 \text{ s}$
period of revolution about Sun .....	$= 3.16 \times 10^7 \text{ s}$
mass .....	$= 5.98 \times 10^{24} \text{ kg}$
<b>Moon</b>	
radius .....	$= 1.74 \times 10^6 \text{ m}$
radius of orbit about Earth .....	$= 3.84 \times 10^8 \text{ m}$
period of rotation .....	$= 2.36 \times 10^6 \text{ s}$
period of revolution about Earth .....	$= 2.36 \times 10^6 \text{ s}$
mass .....	$= 7.35 \times 10^{22} \text{ kg}$
<b>Sun</b>	
mass .....	$= 1.98 \times 10^{30} \text{ kg}$
Constant in Coulomb's Law .....	$k = 9.00 \times 10^9 \text{ N} \cdot \text{m}^2/\text{C}^2$
Elementary charge .....	$e = 1.60 \times 10^{-19} \text{ C}$
Mass of electron .....	$m_e = 9.11 \times 10^{-31} \text{ kg}$
Mass of proton .....	$m_p = 1.67 \times 10^{-27} \text{ kg}$
Mass of neutron .....	$m_n = 1.68 \times 10^{-27} \text{ kg}$
Permeability of free space .....	$\mu_o = 4\pi \times 10^{-7} \text{ T} \cdot \text{m/A}$
Speed of light .....	$c = 3.00 \times 10^8 \text{ m/s}$

**You may detach this page for convenient reference.  
Exercise care when tearing along perforations.**

## MATHEMATICAL EQUATIONS

### For Right-angled Triangles:

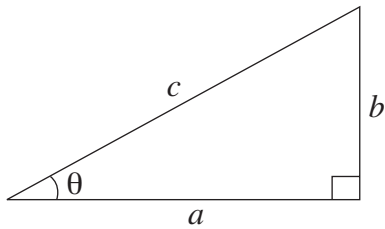

$$a^2 + b^2 = c^2$$

$$\sin \theta = \frac{b}{c} \quad \cos \theta = \frac{a}{c} \quad \tan \theta = \frac{b}{a}$$

$$\text{area} = \frac{1}{2} ab$$

### For All Triangles:

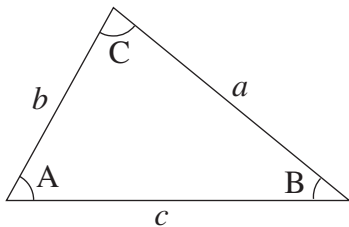

$$\text{area} = \frac{1}{2} \text{base} \times \text{height}$$

$$\sin 2A = 2 \sin A \cos A$$

$$\text{Sine Law: } \frac{\sin A}{a} = \frac{\sin B}{b} = \frac{\sin C}{c}$$

$$\text{Cosine Law: } c^2 = a^2 + b^2 - 2ab \cos C$$

### Circle:

$$\text{Circumference} = 2\pi r$$

$$\text{Area} = \pi r^2$$

### Sphere:

$$\text{Surface area} = 4\pi r^2$$

$$\text{Volume} = \frac{4}{3} \pi r^3$$

### Quadratic Equation:

$$\text{If } ax^2 + bx + c = 0, \text{ then } x = \frac{-b \pm \sqrt{b^2 - 4ac}}{2a}$$



**Vector Kinematics in Two Dimensions:**

$$v = v_0 + at \qquad \bar{v} = \frac{v + v_0}{2}$$

$$v^2 = v_0^2 + 2ad \qquad d = v_0t + \frac{1}{2}at^2$$

**Vector Dynamics:**

$$F_{\text{net}} = ma \qquad F_g = mg$$

$$F_{\text{fr}} = \mu F_N$$

**Work, Energy, and Power:**

$$W = Fd \qquad E_p = mgh$$

$$E_k = \frac{1}{2}mv^2 \qquad P = \frac{W}{t}$$

**Momentum:**

$$p = mv \qquad \Delta p = F\Delta t$$

**Equilibrium:**

$$\tau = Fd$$

**Circular Motion:**

$$a_c = \frac{v^2}{r} = \frac{4\pi^2 r}{T^2}$$

**Gravitation:**

$$F = G \frac{m_1 m_2}{r^2} \qquad E_p = -G \frac{m_1 m_2}{r}$$

You may detach this page for convenient reference.  
Exercise care when tearing along perforations.

### Electrostatics:

$$F = k \frac{Q_1 Q_2}{r^2} \quad E = \frac{F}{Q}$$

$$\Delta V = \frac{\Delta E_p}{Q} \quad E = \frac{\Delta V}{d}$$

$$E_p = k \frac{Q_1 Q_2}{r} \quad V = \frac{kQ}{r}$$

### Electric Circuits:

$$I = \frac{Q}{t} \quad V = IR$$

$$V_{\text{terminal}} = \mathcal{E} \pm Ir \quad P = IV$$

### Electromagnetism:

$$F = BIl \quad F = QvB$$

$$B = \mu_0 n I = \mu_0 \frac{N}{l} I \quad \mathcal{E} = Blv$$

$$\Phi = BA \quad \mathcal{E} = -N \frac{\Delta \Phi}{\Delta t}$$

$$V_{\text{back}} = \mathcal{E} - Ir$$

$$\frac{V_s}{V_p} = \frac{N_s}{N_p} = \frac{I_p}{I_s}$$

**ROUGH WORK FOR MULTIPLE-CHOICE**

**You may detach this page for convenient reference.  
Exercise care when tearing along perforations.**

## ROUGH WORK FOR MULTIPLE-CHOICE