

**JANUARY 1998**

## **PROVINCIAL EXAMINATION**

---

**MINISTRY OF EDUCATION, SKILLS AND TRAINING**

# **PHYSICS 12**

### **GENERAL INSTRUCTIONS**

1. Insert the stickers with your Student I.D. Number (PEN) in the allotted spaces above and on the **back** cover of this booklet. **Under no circumstance is your name or identification, other than your Student I.D. Number, to appear on this booklet.**
2. Ensure that in addition to this examination booklet, you have an **Examination Response Form**. Follow the directions on the front of the Response Form.
3. **Disqualification** from the examination will result if you bring books, paper, notes or unauthorized electronic devices into the examination room.
4. All multiple-choice answers must be entered on the Response Form using an **HB pencil**. Multiple-choice answers entered in this examination booklet will **not** be marked.
5. For each of the written-response questions, write your answer in the space provided in this booklet.
6. When instructed to open this booklet, **check the numbering of the pages** to ensure that they are numbered in sequence from page one to the last page, which is identified by

**END OF EXAMINATION**.

7. At the end of the examination, place your Response Form inside the front cover of this booklet and return the booklet and your Response Form to the supervisor.

**THIS PAGE INTENTIONALLY BLANK**

## PHYSICS 12 PROVINCIAL EXAMINATION

	Value	Suggested Time
1. This examination consists of <b>two</b> parts:		
PART A: 30 multiple-choice questions worth two marks each	60	60
PART B: 9 written-response questions	60	60
	<b>Total: 120 marks</b>	<b>120 minutes</b>

- Aside from an approved calculator, electronic devices, including dictionaries and pagers, are **not** permitted in the examination room.
- The last **three** pages inside the back cover contain the **Table of Constants, Mathematical Equations, Formulae, and Rough Work for Multiple-Choice**. These pages may be detached for convenient reference prior to writing this examination.
- Rough-work space has been incorporated into the space allowed for answering each written-response question. You may not need all of the space provided to answer each question.
- A calculator is essential for the Physics 12 Provincial Examination.** The calculator must be a hand-held device designed primarily for mathematical computations involving logarithmic and trigonometric functions. Computers, calculators with a QWERTY keyboard, and electronic writing pads will not be allowed. Students must not bring any external devices to support calculators such as manuals, printed or electronic cards, printers, memory expansion chips or cards, or external keyboards. Students may have more than one calculator available during the examination. Calculators may not be shared, and communication between calculators is prohibited during the examination. In addition to an approved calculator, students will be allowed to use rulers, compasses, and protractors during the examination.
- Final answers must include appropriate **units**.
  - Marks will not be deducted for answers expressed to **two** or **three** significant figures.
  - In this examination the zero in a number such as 30 shall be considered to be a significant zero.
- You are expected to communicate your knowledge and understanding of physics principles in a clear and logical manner. Partial marks will be awarded for steps and assumptions leading to a solution. Full marks will **not** be awarded for providing **only** a final answer.

If you are unable to determine the value of a quantity required in order to proceed, you may assume a reasonable value and continue toward the solution. Such a solution, however, may not be eligible for full marks.

- The time allotted for this examination is **two hours**.

**THIS PAGE INTENTIONALLY BLANK**

**PART A: MULTIPLE CHOICE**

**Value: 60 marks (2 marks per question)**

**Suggested Time: 60 minutes**

**INSTRUCTIONS:** For each question, select the **best** answer and record your choice on the Response Form provided. Using an HB pencil, completely fill in the circle that has the letter corresponding to your answer.

1. The diagram shows the vertical and horizontal components of a force,  $\vec{F}_V$  and  $\vec{F}_H$ .

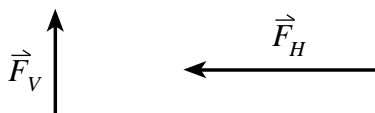

Which of the following is their resultant force  $\vec{F}$  ?

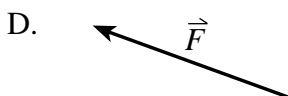
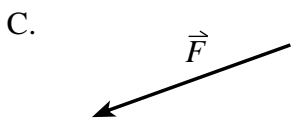
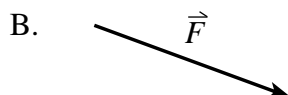
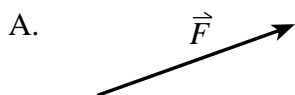

2. Which of the following are the units for gravitational field strength?

- A. N
- B. N/m
- C. N/kg
- D.  $\text{N} \cdot \text{m}^2/\text{kg}^2$

3. A ball is thrown from level ground at 24 m/s,  $30^\circ$  above horizontal. How much time will it take to reach its maximum height?

- A. 1.2 s
- B. 2.1 s
- C. 2.4 s
- D. 7.3 s

**OVER**

4. A student exerts a 120 N horizontal force on a 25 kg carton of apples, causing it to accelerate over level ground at  $1.8 \text{ m/s}^2$ .

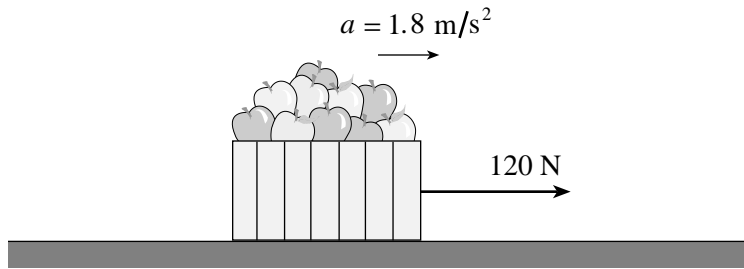

Find the coefficient of friction between the carton and the ground.

- A. 0.31  
B. 0.38  
C. 0.49  
D. 0.67
5. A net force  $F$  acts on an object of mass  $m$ , causing it to accelerate at  $4.0 \text{ m/s}^2$ . If the same net force  $F$  acts on an object of mass  $2m$ , its acceleration will be
- A.  $1.0 \text{ m/s}^2$   
B.  $2.0 \text{ m/s}^2$   
C.  $4.0 \text{ m/s}^2$   
D.  $8.0 \text{ m/s}^2$
6. Which of the following is a definition of power?
- A. Power is the rate of change of flux.  
B. Power is the rate of change of energy.  
C. Power is the rate of change of momentum.  
D. Power is the rate of change of displacement.

7. Two blocks are initially held together on a frictionless surface as shown in the diagram below.

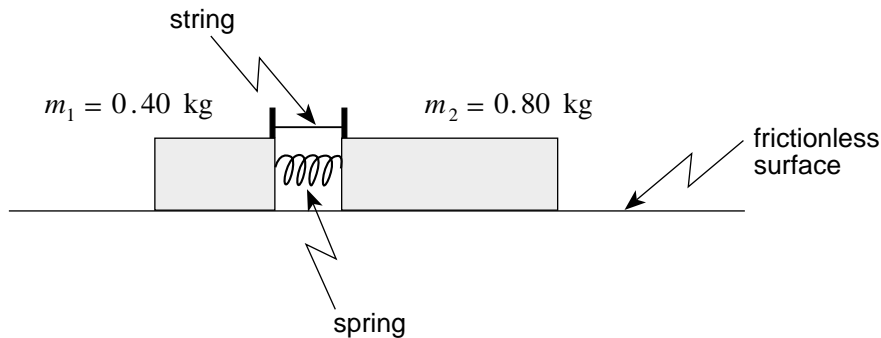

When the string is cut, the blocks fly apart as shown.

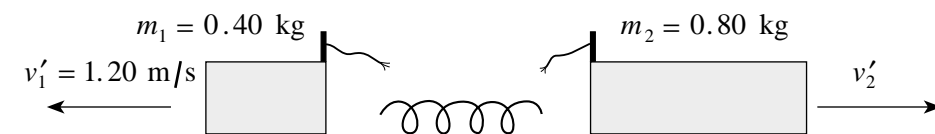

What work was done on the blocks by the spring?

- A. 0 J
  - B. 0.29 J
  - C. 0.43 J
  - D. 0.58 J
8. A ball is thrown at 15 m/s towards various barriers. In which case does the ball experience the greatest impulse?
- A. The ball hits a wall and rebounds at 2.0 m/s.
  - B. The ball hits a wall and rebounds at 7.0 m/s.
  - C. The ball hits a wall, sticks to it and stops moving.
  - D. The ball breaks a window and continues moving at 10 m/s in the same direction.
9. State the condition for **translational** equilibrium.
- A.  $\Sigma F = 0$
  - B.  $\Sigma F \neq 0$
  - C.  $\Sigma \tau = 0$
  - D.  $\Sigma \tau \neq 0$

10. An 85.0 kg mountaineer remains in equilibrium while climbing a vertical cliff. The tension force in the supporting rope is 745 N.

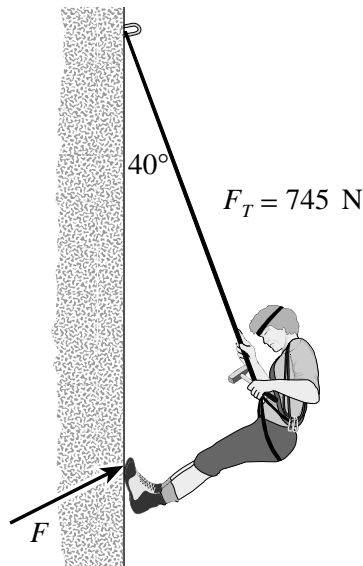

Find the magnitude of the reaction force,  $F$ , which the cliff exerts on the mountaineer's feet.

- A. 88.0 N
  - B. 373 N
  - C. 479 N
  - D. 546 N
11. A uniform 15 kg pipe of length 5.0 m has a 160 N force applied 4.0 m from its lower end as shown.

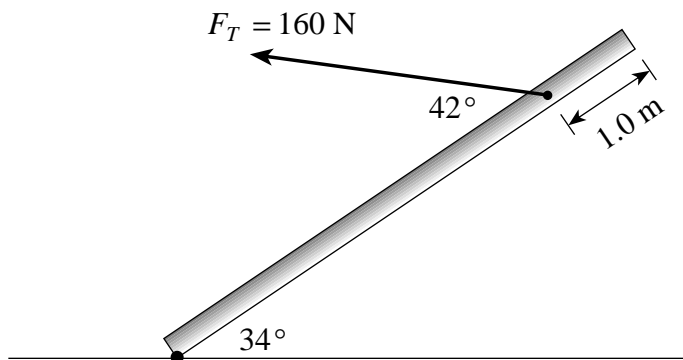

Using the point where the pipe touches the ground as a pivot, calculate the sum of the torques acting on the pipe.

- A. 180 N · m in a clockwise direction.
- B. 270 N · m in a clockwise direction.
- C. 120 N · m in a counter-clockwise direction.
- D. 270 N · m in a counter-clockwise direction.



12. A car moving in a circular path with a constant speed has

- A. no acceleration.
- B. outward acceleration.
- C. tangential acceleration.
- D. centripetal acceleration.

13. A person is moving at constant speed in a vertical circular path.

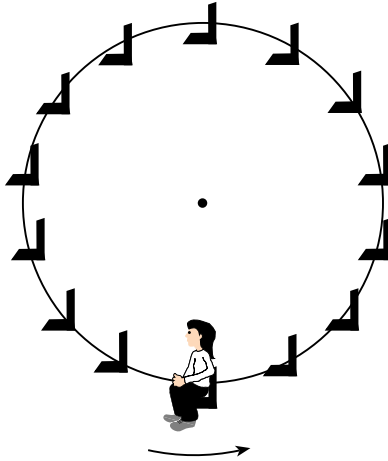

Which is the correct free body diagram for the person while passing through the lowest point?

A.



B.

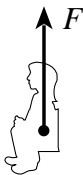

C.

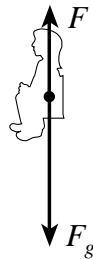

D.

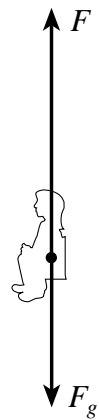

14. A  $9.0 \times 10^{-3}$  kg ball is attached to a  $3.6 \times 10^{-2}$  kg mass M by a string that passes through a hole in a horizontal frictionless surface. The ball travels in a circular path of radius 0.35 m.

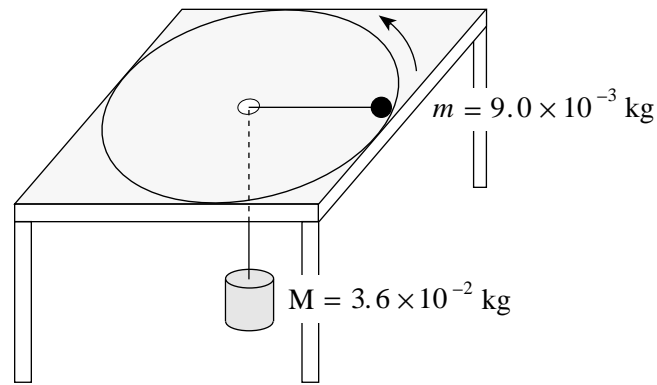

What is the speed of the ball?

- A. 0.93 m/s  
 B. 1.9 m/s  
 C. 3.7 m/s  
 D. 4.1 m/s
15. A space station has an outer radius of 140 m. The station rotates so that the occupants at X at the outer wall experience an acceleration of  $9.8 \text{ m/s}^2$ . What acceleration will the occupants at Y experience at the 100 m radius?

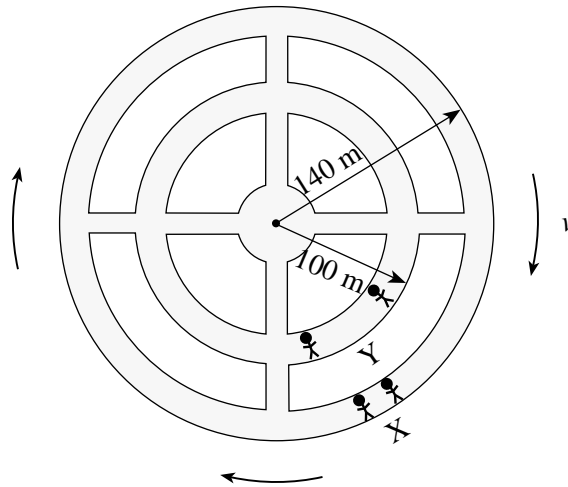

- A.  $7.0 \text{ m/s}^2$   
 B.  $8.3 \text{ m/s}^2$   
 C.  $9.8 \text{ m/s}^2$   
 D.  $14 \text{ m/s}^2$

16. Which of the following graphs shows how the gravitational field of a body varies with distance from its centre? (Assume  $d$  is greater than the radius of the body.)

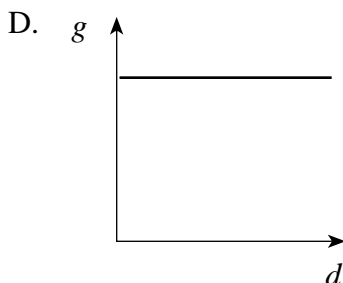
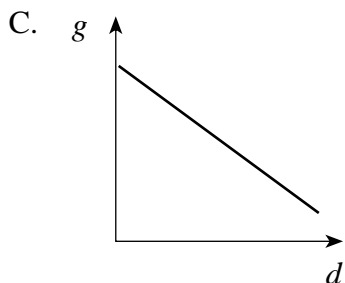
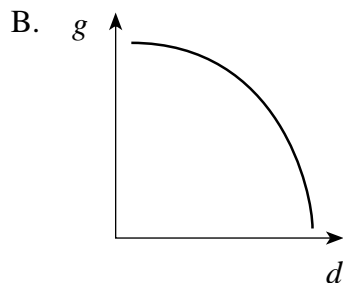
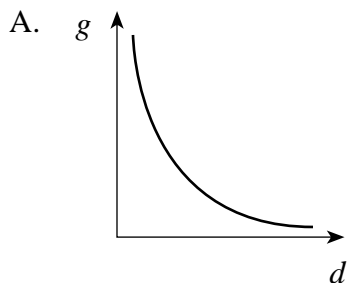

17. A  $9.0 \times 10^3$  kg satellite with an orbital radius of  $3.20 \times 10^7$  m orbits the earth at an altitude of  $2.56 \times 10^7$  m. What is the orbital period?

- A.  $1.1 \times 10^4$  s
- B.  $4.1 \times 10^4$  s
- C.  $5.7 \times 10^4$  s
- D.  $1.5 \times 10^{15}$  s

18. A cathode ray tube is adjusted so as to deflect the beam as shown.

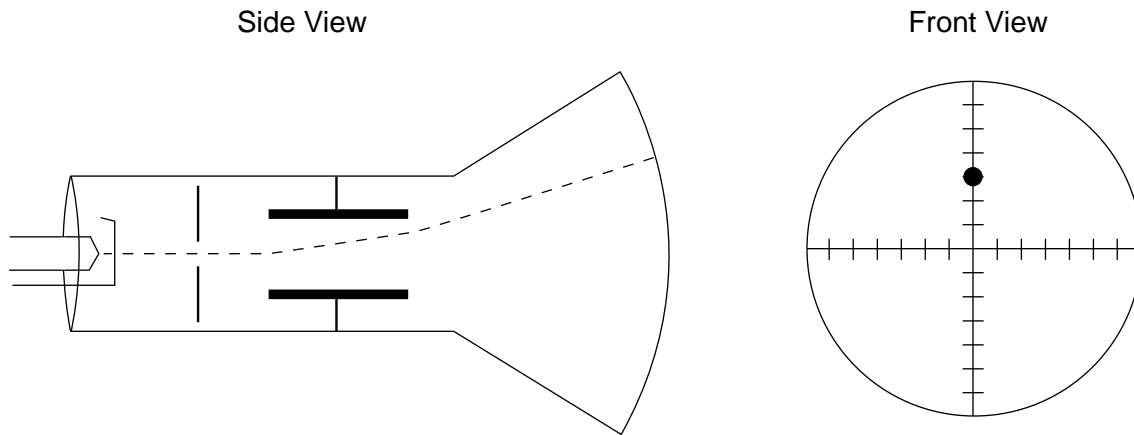

If the deflecting voltage is held constant and the accelerating voltage is then **decreased**, which diagram displays the new deflection?

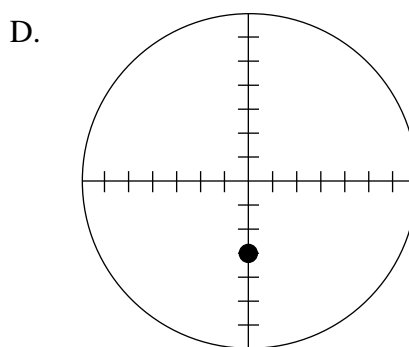
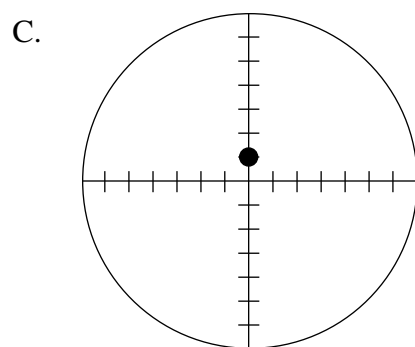
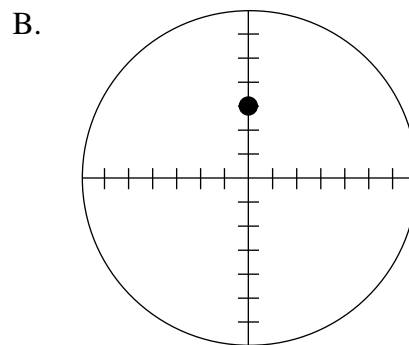
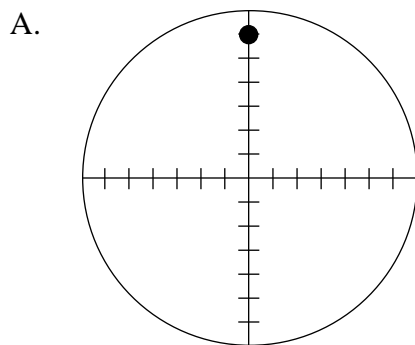

19. What is the change in **kinetic energy** of an electron that moves from the negative plate to the positive plate in the situation shown below?

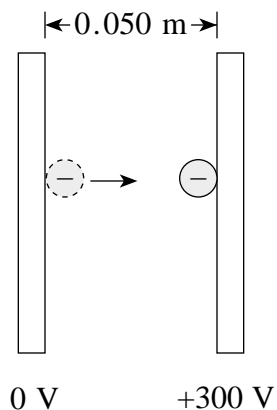

- A. A gain of  $4.8 \times 10^{-17}$  J  
 B. A loss of  $4.8 \times 10^{-17}$  J  
 C. A gain of  $9.6 \times 10^{-16}$  J  
 D. A loss of  $9.6 \times 10^{-16}$  J
20. Two  $2.0 \times 10^{-6}$  C charges are positioned as shown in the diagram below.

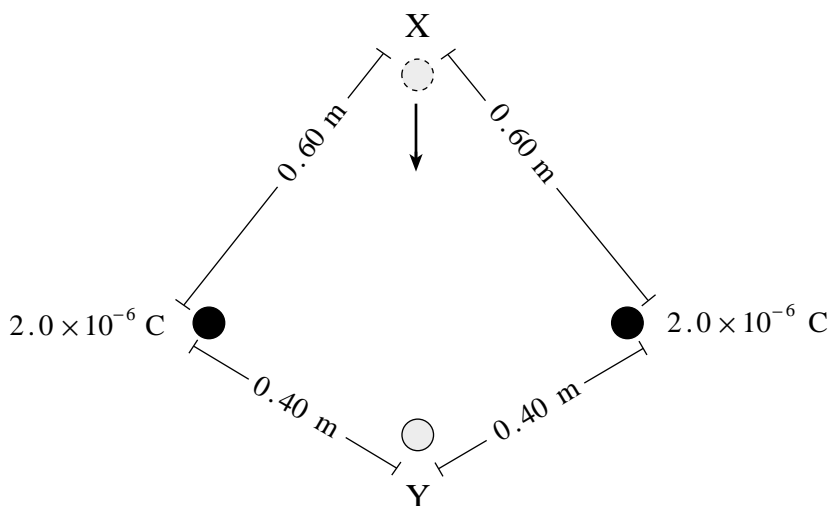

What work must be done to move a  $1.2 \times 10^{-7}$  C charge from location X to location Y?

- A.  $3.6 \times 10^{-3}$  J  
 B.  $1.5 \times 10^{-2}$  J  
 C.  $1.8 \times 10^{-2}$  J  
 D.  $3.9 \times 10^{-2}$  J

21. Which of the following statements provides valid reasoning for the transmission of electric energy at high potential?

- A. At high potential there will be low current resulting in low power loss.
- B. At high potential there will be high current resulting in high power loss.
- C. At high potential there will be low line resistance resulting in low power loss.
- D. At high potential there will be high line resistance resulting in high power loss.

22. What is the terminal voltage of the battery in the circuit shown in the diagram?

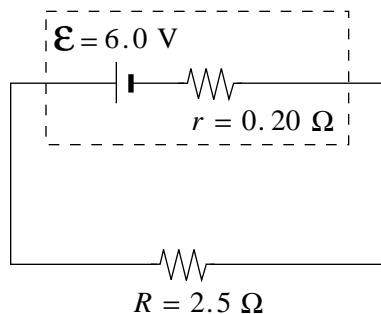

- A. 0.44 V
- B. 5.6 V
- C. 6.0 V
- D. 6.4 V

23. What is the power dissipated in the unknown resistor  $R_x$  in the circuit below?

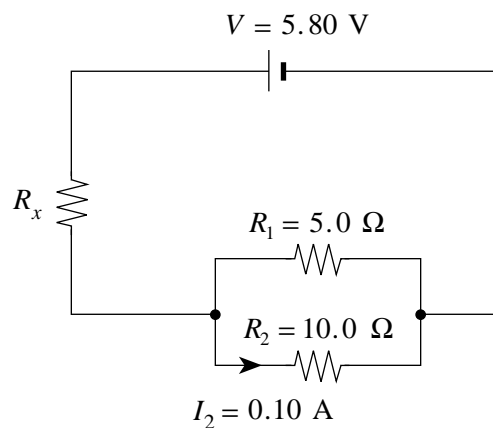

- A. 0.30 W
- B. 1.4 W
- C. 1.7 W
- D. 2.0 W

24. A compass is positioned at each of the following locations near a bar magnet.

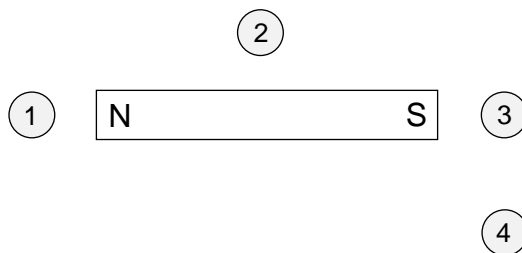

In which location will the compass needle point to the right-hand side of the page?

- A. 1
- B. 2
- C. 3
- D. 4

25. A current-carrying conductor is placed in a uniform magnetic field as shown.

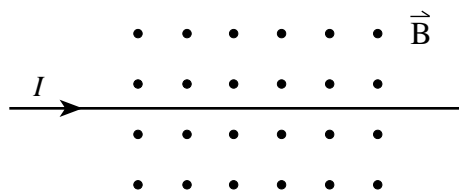

What is the direction of the magnetic force on this conductor?

- A. Into the page
- B. Out of the page
- C. Towards the top of the page
- D. Towards the bottom of the page

26. A 5.0 A current flows through a 0.20 m long solenoid that contains 1 500 loops.

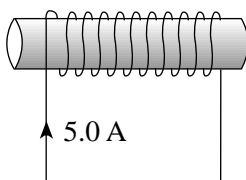

What are the magnitude and direction of the magnetic field at the centre of the solenoid?

	MAGNITUDE	DIRECTION
A.	$9.4 \times 10^{-3}$ T	left
B.	$9.4 \times 10^{-3}$ T	right
C.	$4.7 \times 10^{-2}$ T	left
D.	$4.7 \times 10^{-2}$ T	right

**OVER**

27. Four conductors of different lengths are moved through a uniform magnetic field at the same speed.

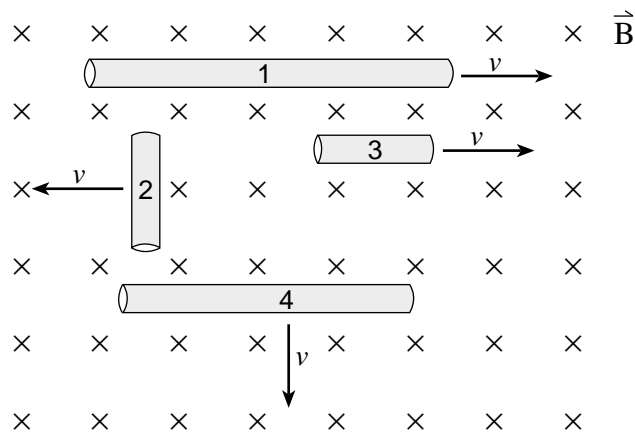

Which conductor will induce the greatest emf?

- A. 1  
 B. 2  
 C. 3  
 D. 4
28. A motor has an armature resistance of  $3.5 \Omega$  and is connected to a  $12.0 \text{ V}$  source. At full speed the current through the armature is  $0.18 \text{ A}$ . What is the back emf at full speed?
- A.  $0 \text{ V}$   
 B.  $0.63 \text{ V}$   
 C.  $11.4 \text{ V}$   
 D.  $12.0 \text{ V}$
29. A **step-down** transformer has a  $500$  turn primary that operates at  $120 \text{ V ac}$ . Which of the following sets of conditions best describes the number of secondary turns and secondary voltage of this transformer?

	SECONDARY TURNS	SECONDARY VOLTAGE
A.	40	$9.6 \text{ V ac}$
B.	40	$1\,500 \text{ V ac}$
C.	2 000	$30 \text{ V ac}$
D.	2 000	$480 \text{ V ac}$



30. A flexible loop of wire of area  $4.5 \times 10^{-2} \text{ m}^2$  is positioned in a  $0.17 \text{ T}$  magnetic field as shown in Figure A. The loop is then stretched until its area is zero in a time of  $0.35 \text{ s}$  (Figure B). What is the average induced emf in the circuit and the direction of the current through resistor R?

Figure A

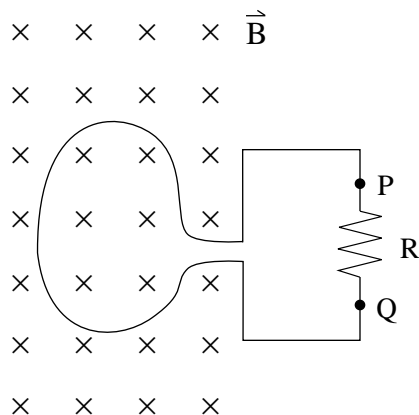
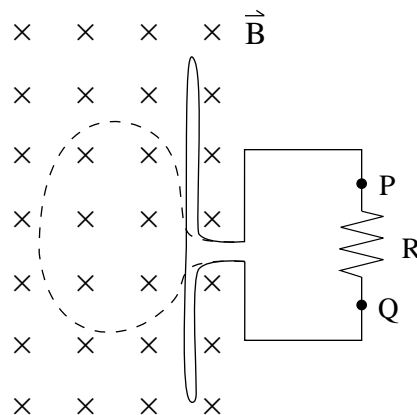

Figure B



	AVERAGE EMF	DIRECTION OF CURRENT THROUGH R
A.	$2.2 \times 10^{-2} \text{ V}$	P to Q
B.	$2.2 \times 10^{-2} \text{ V}$	Q to P
C.	$4.9 \times 10^{-1} \text{ V}$	P to Q
D.	$4.9 \times 10^{-1} \text{ V}$	Q to P

**This is the end of the multiple-choice section.**  
**Answer the remaining questions directly in this examination booklet.**

**THIS PAGE INTENTIONALLY BLANK**

## PART B: WRITTEN RESPONSE

Value: 60 marks

Suggested Time: 60 minutes

### INSTRUCTIONS:

1. Rough-work space has been incorporated into the space allowed for answering each written-response question. You may not need all of the space provided to answer each question.
2.
  - a) Final answers must include appropriate **units**.
  - b) Marks will not be deducted for answers expressed to **two** or **three** significant figures.
  - c) In this examination the zero in a number such as 30 shall be considered to be a significant zero.
3. You are expected to communicate your knowledge and understanding of physics principles in a clear and logical manner. Partial marks will be awarded for steps and assumptions leading to a solution. Full marks will **not** be awarded for providing a final answer **only**.
4. If you are unable to determine the value of a quantity required in order to proceed, you may assume a reasonable value and continue toward the solution. Such a solution, however, may not be eligible for full marks.

**Full marks will NOT be given for the final answer only.**

1. A student drags a 7.0 kg carton of apples across the floor by exerting a 45 N force in the direction shown. The coefficient of friction between the carton and the floor is 0.52.

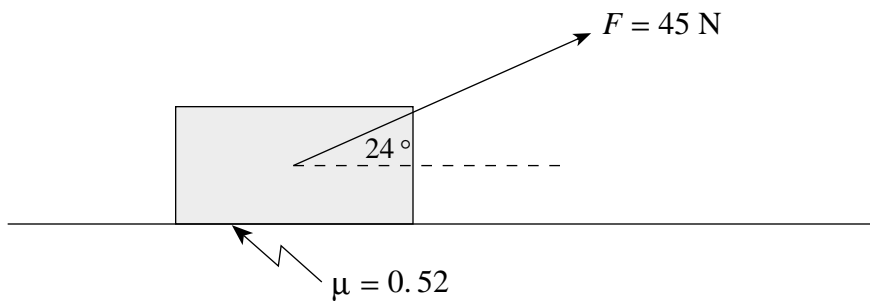

- a) What is the magnitude of the normal force acting on the carton?

**(2 marks)**

b) What friction force acts on the carton?

**(2 marks)**

c) What is the acceleration of the carton?

**(3 marks)**

ANSWER:

a) normal force: \_\_\_\_\_

b) friction force: \_\_\_\_\_

c) acceleration: \_\_\_\_\_

**OVER**

2. A 7.0 kg object moving at 12 m/s to the east explodes into two unequal fragments. The larger 5.0 kg fragment moves at 15 m/s south.

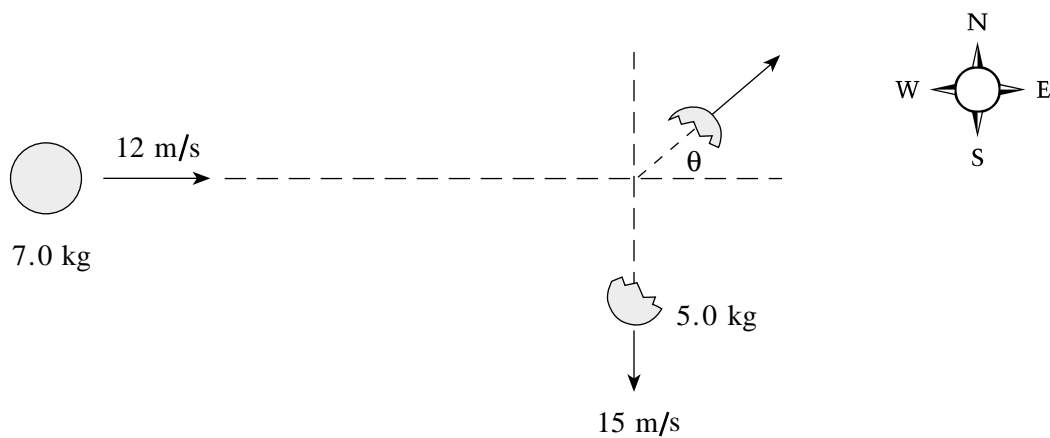

What is the velocity (speed and direction) of the smaller 2.0 kg fragment?

**(7 marks)**

ANSWER:  
speed: \_\_\_\_\_  
direction: \_\_\_\_\_

**OVER**

3. A floodlight is suspended from two cables as shown below. The tension in the right cable is 140 N.

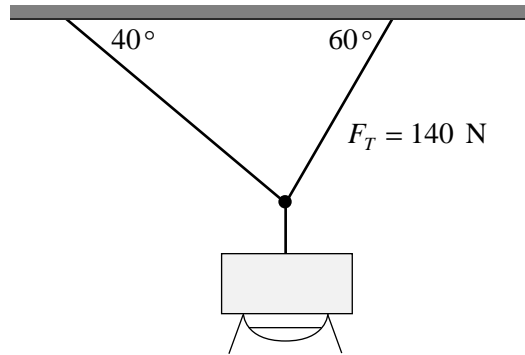

- a) What is the tension in the left cable?

**(3 marks)**



b) What is the mass of the floodlight?

**(4 marks)**

ANSWER:

a) tension: \_\_\_\_\_

b) mass: \_\_\_\_\_

**OVER**

4. A 1 200 kg space probe is in a circular orbit around the Sun. The orbital radius is  $7.0 \times 10^9$  m.

a) What is the orbital speed of this satellite?

**(5 marks)**

b) If the Sun collapsed to one-tenth its present radius without a change to its mass, the space probe's orbital radius will

- increase.
- decrease.
- stay the same.

(Check one response.)

**(1 mark)**

c) Using principles of physics, explain your answer to b).

**(3 marks)**

---

---

---

---

---

---

---

ANSWER:

a) orbital speed: \_\_\_\_\_

5. Calculate the net electric field (magnitude and direction) at point P due to the two point charges shown in the diagram. **(7 marks)**

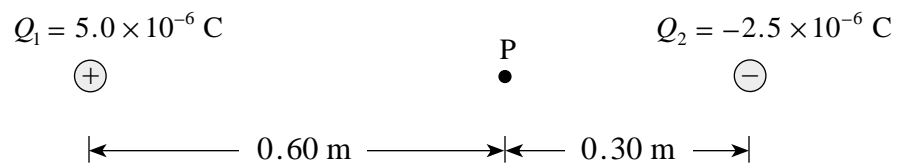

ANSWER:  
magnitude: \_\_\_\_\_  
direction: \_\_\_\_\_

6. Consider the circuit shown below.

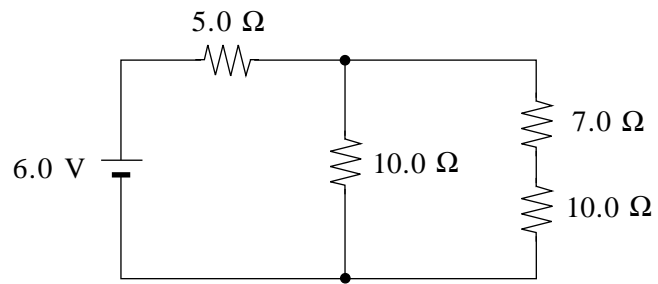

a) What is the current through the  $7.0 \Omega$  resistor?

**(5 marks)**

b) How much charge flows through the  $7.0 \Omega$  resistor in a 30 s interval?

**(2 marks)**

ANSWER:

a) current: \_\_\_\_\_

b) charge: \_\_\_\_\_

**OVER**

7. An electron is accelerated from rest through a potential difference of 750 V. It then enters a uniform  $2.3 \times 10^{-3}$  T magnetic field at right angles to the field.

a) What is the speed of the electron?

**(3 marks)**



b) What is the radius of its path in the magnetic field?

**(4 marks)**

ANSWER:

a) speed: \_\_\_\_\_

b) radius: \_\_\_\_\_

8. A student connects a power supply to a circuit and measures the potential difference  $V$  at its terminals and the current  $I$  delivered to the circuit.

$V$ (V)	0.0	3.0	6.0	9.0	12.0
$I$ (A)	0.00	0.25	0.50	0.75	1.00

a) Plot a graph of  $V$  versus  $I$  on the axes below.

**(2 marks)**

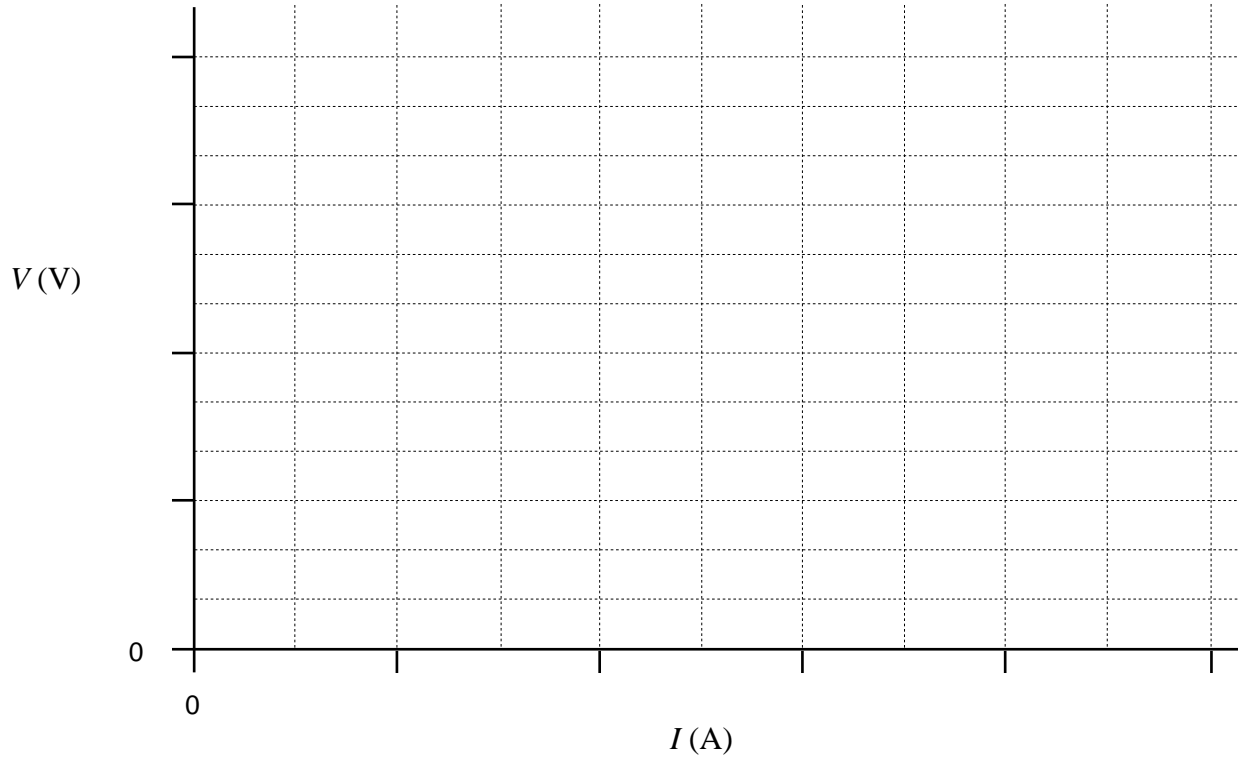

b) Calculate the slope of the line, expressing your answer in appropriate units. **(2 marks)**

c) What does the slope of the line represent? **(1 mark)**

---

---

ANSWER:

b) slope: \_\_\_\_\_

9. A roller coaster car is released from the crest of a hill.

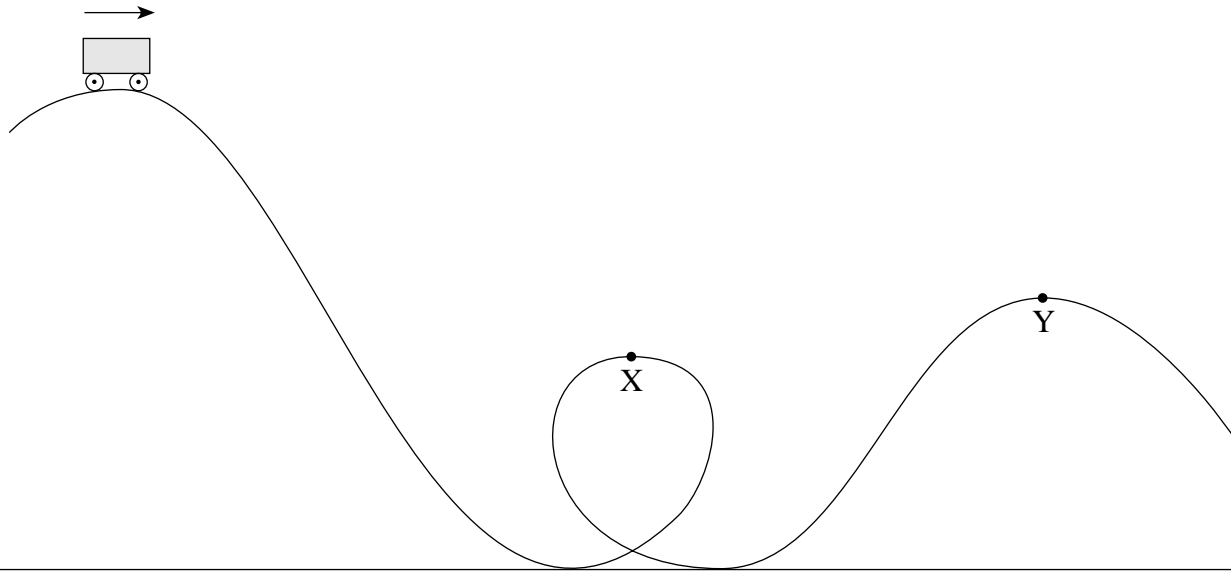

a) How does the speed at Y compare to the speed at X? Ignore friction. (Check one response.) **(1 mark)**

- The speed at Y is equal to the speed at X.
- The speed at Y is less than the speed at X.
- The speed at Y is greater than the speed at X.

b) Using principles of physics, explain your answer to a). **(3 marks)**

---

---

---

---

---

---

---

**END OF EXAMINATION**

## TABLE OF CONSTANTS

Gravitational constant .....	$G = 6.67 \times 10^{-11} \text{ N} \cdot \text{m}^2/\text{kg}^2$
Acceleration due to gravity at the surface of Earth (for the purposes of this examination) .....	$g = 9.80 \text{ m/s}^2$
<b>Earth</b>	
radius .....	$= 6.38 \times 10^6 \text{ m}$
radius of orbit about Sun .....	$= 1.50 \times 10^{11} \text{ m}$
period of rotation .....	$= 8.61 \times 10^4 \text{ s}$
period of revolution about Sun .....	$= 3.16 \times 10^7 \text{ s}$
mass .....	$= 5.98 \times 10^{24} \text{ kg}$
<b>Moon</b>	
radius .....	$= 1.74 \times 10^6 \text{ m}$
radius of orbit about Earth .....	$= 3.84 \times 10^8 \text{ m}$
period of rotation .....	$= 2.36 \times 10^6 \text{ s}$
period of revolution about Earth .....	$= 2.36 \times 10^6 \text{ s}$
mass .....	$= 7.35 \times 10^{22} \text{ kg}$
<b>Sun</b>	
mass .....	$= 1.98 \times 10^{30} \text{ kg}$
Constant in Coulomb's Law .....	$k = 9.00 \times 10^9 \text{ N} \cdot \text{m}^2/\text{C}^2$
Elementary charge .....	$e = 1.60 \times 10^{-19} \text{ C}$
Mass of electron .....	$m_e = 9.11 \times 10^{-31} \text{ kg}$
Mass of proton .....	$m_p = 1.67 \times 10^{-27} \text{ kg}$
Mass of neutron .....	$m_n = 1.68 \times 10^{-27} \text{ kg}$
Permeability of free space .....	$\mu_o = 4\pi \times 10^{-7} \text{ T} \cdot \text{m/A}$
Speed of light .....	$c = 3.00 \times 10^8 \text{ m/s}$

**You may detach this page for convenient reference.  
Exercise care when tearing along perforations.**

## MATHEMATICAL EQUATIONS

### For Right-angled Triangles:

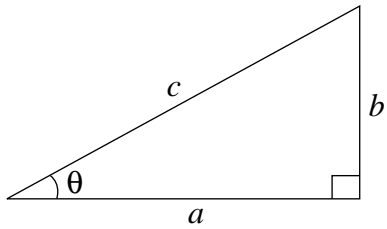

$$a^2 + b^2 = c^2$$

$$\sin \theta = \frac{b}{c} \quad \cos \theta = \frac{a}{c} \quad \tan \theta = \frac{b}{a}$$

$$\text{area} = \frac{1}{2} ab$$

### For All Triangles:

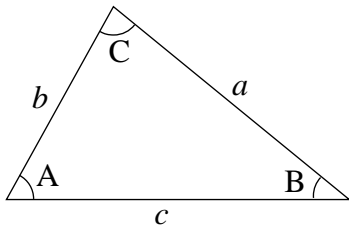

$$\text{area} = \frac{1}{2} \text{base} \times \text{height}$$

$$\sin 2A = 2 \sin A \cos A$$

$$\text{Sine Law: } \frac{\sin A}{a} = \frac{\sin B}{b} = \frac{\sin C}{c}$$

$$\text{Cosine Law: } c^2 = a^2 + b^2 - 2ab \cos C$$

### Circle:

$$\text{Circumference} = 2\pi r$$

$$\text{Area} = \pi r^2$$

### Sphere:

$$\text{Surface area} = 4\pi r^2$$

$$\text{Volume} = \frac{4}{3}\pi r^3$$

### Quadratic Equation:

$$\text{If } ax^2 + bx + c = 0, \text{ then } x = \frac{-b \pm \sqrt{b^2 - 4ac}}{2a}$$

**Vector Kinematics in Two Dimensions:**

$$v = v_0 + at \quad \bar{v} = \frac{v + v_0}{2}$$

$$v^2 = v_0^2 + 2ad \quad d = v_0t + \frac{1}{2}at^2$$

**Vector Dynamics:**

$$F_{\text{net}} = ma \quad F_g = mg$$

$$F_{\text{fr}} = \mu F_N$$

**Work, Energy, and Power:**

$$W = Fd \quad E_p = mgh$$

$$E_k = \frac{1}{2}mv^2 \quad P = \frac{W}{t}$$

**Momentum:**

$$p = mv \quad \Delta p = F\Delta t$$

**Equilibrium:**

$$\tau = Fd$$

**Circular Motion:**

$$a_c = \frac{v^2}{r} = \frac{4\pi^2 r}{T^2}$$

**Gravitation:**

$$F = G \frac{m_1 m_2}{r^2} \quad E_p = -G \frac{m_1 m_2}{r}$$

**You may detach this page for convenient reference.  
Exercise care when tearing along perforations.**

### Electrostatics:

$$F = k \frac{Q_1 Q_2}{r^2} \quad E = \frac{F}{Q}$$

$$\Delta V = \frac{\Delta E_p}{Q} \quad E = \frac{\Delta V}{d}$$

$$E_p = k \frac{Q_1 Q_2}{r} \quad V = \frac{kQ}{r}$$

### Electric Circuits:

$$I = \frac{Q}{t} \quad V = IR$$

$$V_{\text{terminal}} = \mathcal{E} \pm Ir \quad P = IV$$

### Electromagnetism:

$$F = BIl \quad F = QvB$$

$$B = \mu_0 nI = \mu_0 \frac{N}{l} I \quad \mathcal{E} = Blv$$

$$\Phi = BA \quad \mathcal{E} = -N \frac{\Delta \Phi}{\Delta t}$$

$$V_{\text{back}} = \mathcal{E} - Ir$$

$$\frac{V_s}{V_p} = \frac{N_s}{N_p} = \frac{I_p}{I_s}$$



**ROUGH WORK FOR MULTIPLE-CHOICE**

**You may detach this page for convenient reference.  
Exercise care when tearing along perforations.**

# ROUGH WORK FOR MULTIPLE-CHOICE



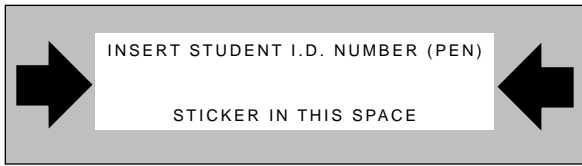

# **PHYSICS 12**

**January 1998**

Course Code = PH

FOR OFFICE USE ONLY

# PHYSICS 12

January 1998

Course Code = PH

Score for  
Question 1:

1.  $\frac{\quad}{(7)}$

Score for  
Question 8:

8.  $\frac{\quad}{(5)}$

Score for  
Question 2:

2.  $\frac{\quad}{(7)}$

Score for  
Question 9:

9.  $\frac{\quad}{(4)}$

Score for  
Question 3:

3.  $\frac{\quad}{(7)}$

Score for  
Question 4:

4.  $\frac{\quad}{(9)}$

Score for  
Question 5:

5.  $\frac{\quad}{(7)}$

Score for  
Question 6:

6.  $\frac{\quad}{(7)}$

Score for  
Question 7:

7.  $\frac{\quad}{(7)}$