

**JANUARY 1997**

## **PROVINCIAL EXAMINATION**

---

**MINISTRY OF EDUCATION, SKILLS AND TRAINING**

# **PHYSICS 12**

### **GENERAL INSTRUCTIONS**

1. Insert the stickers with your Student I.D. Number (PEN) in the allotted spaces above. **Under no circumstance is your name or identification, other than your Student I.D. Number, to appear on this paper.**
2. Take the separate Answer Sheet and follow the directions on its front page.
3. Be sure you have an HB pencil and an eraser for completing your Answer Sheet. Follow the directions on the Answer Sheet when answering multiple-choice questions.
4. For each of the written-response questions, write your answer in the space provided.
5. When instructed to open this booklet, **check the numbering of the pages** to ensure that they are numbered in sequence from page one to the last page, which is identified by **END OF EXAMINATION**.
6. At the end of the examination, place your Answer Sheet inside the front cover of this booklet and return the booklet and your Answer Sheet to the supervisor.

**THIS PAGE INTENTIONALLY BLANK**

**FOR OFFICE USE ONLY**

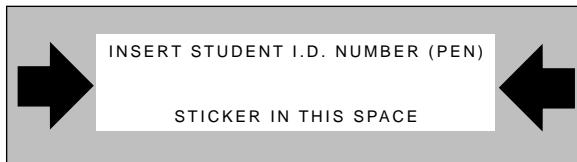

\_\_\_\_\_ - \_\_\_\_\_

**PHYSICS 12 JANUARY 1997 PROVINCIAL**

**Course Code = PH Examination Type = P**

1. \_\_\_\_\_  
(9)

5. \_\_\_\_\_  
(7)

2. \_\_\_\_\_  
(7)

6. \_\_\_\_\_  
(7)

3. \_\_\_\_\_  
(7)

7. \_\_\_\_\_  
(4)

4. \_\_\_\_\_  
(7)

Score **only one** of the following sections.

Section I

Section II

Section III

8. \_\_\_\_\_  
(3)

11. \_\_\_\_\_  
(3)

14. \_\_\_\_\_  
(3)

9. \_\_\_\_\_ **or**

12. \_\_\_\_\_ **or**

15. \_\_\_\_\_  
(4)

10. \_\_\_\_\_  
(5)

13. \_\_\_\_\_  
(5)

16. \_\_\_\_\_  
(5)

**THIS PAGE INTENTIONALLY BLANK**

## PHYSICS 12 PROVINCIAL EXAMINATION

	Value	Suggested Time
1. This examination consists of <b>three</b> parts:		
PART A: 30 multiple-choice questions worth two marks each	60	60
PART B: 7 written-response questions	48	48
PART C: Elected topics consisting of only written-response questions. Answer <b>only one</b> section.	12	12
	<b>Total: 120 marks</b>	<b>120 minutes</b>

- The last **three** pages inside the back cover contain the **Data Table, Trigonometric and Other Equations, Equations, and Rough Work for Multiple-Choice**. These pages may be detached for convenient reference prior to writing this examination.
- Rough-work space has been incorporated into the space allowed for answering each written-response question. You may not need all of the space provided to answer each question.
- An approved scientific calculator is essential for the examination. The calculator must be a hand-held device designed **only** for mathematical computations such as logarithmic and trigonometric functions. It **can be** programmable, but **must not** contain any graphing capabilities. You **must not** bring into the examination room any devices to support calculators such as manuals, printed or electronic cards, printers, memory expansion chips or cards, or keyboards.
- You are permitted to use rulers, compasses and protractors.
- Final answers must include appropriate **units**.
  - Marks will not be deducted for answers expressed to **two** or **three** significant figures.
  - In this examination the zero in a number such as 30 shall be considered to be a significant zero.
- You are expected to communicate your knowledge and understanding of physics principles in a clear and logical manner. Partial marks will be awarded for steps and assumptions leading to a solution. Full marks will **not** be awarded for providing **only** a final answer.

If you are unable to determine the value of a quantity required in order to proceed, you may assume a reasonable value and continue toward the solution. Such a solution, however, may not be eligible for full marks.

8. You have **two hours** to complete this examination.

**THIS PAGE INTENTIONALLY BLANK**



**PART A: MULTIPLE CHOICE**

**Value: 60 marks (2 marks per question)**

**Suggested Time: 60 minutes**

**INSTRUCTIONS:** For each question, select the **best** answer and record your choice on the Answer Sheet provided. Using an HB pencil, completely fill in the circle that has the letter corresponding to your answer.

- 1. Which of the following statements concerning vector and scalar quantities is **incorrect**?
  - A. All scalar quantities have direction.
  - B. All vector quantities have direction.
  - C. All scalar quantities have magnitude.
  - D. All vector quantities have magnitude.

- 2. Two forces act on an object as shown in the diagram.

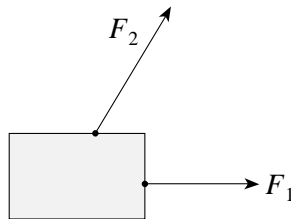

Which of the following **best** shows the resultant **R** of these forces?

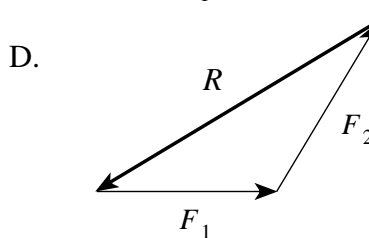
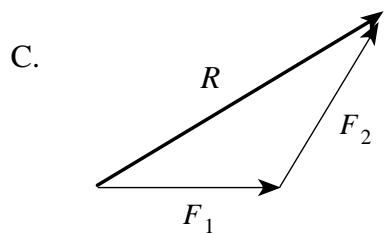
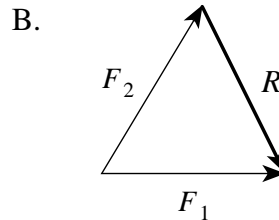
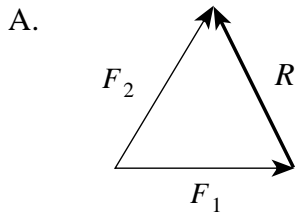

- 3. Starting from rest, a jet takes 25 s and needs 1 500 m of runway to become airborne. What is its speed when it leaves the ground?
  - A. 60 m/s
  - B. 120 m/s

- C. 250 m/s
- D. 1 500 m/s

4. A 75 kg man stands on a scale while accelerating upwards in an elevator. If the scale reads 850 N, what is the magnitude of the acceleration of the elevator?
- A.  $1.2 \text{ m/s}^2$   
 B.  $1.5 \text{ m/s}^2$   
 C.  $9.8 \text{ m/s}^2$   
 D.  $11 \text{ m/s}^2$
5. A 45 kg toboggan and rider decelerate on level snow at  $0.53 \text{ m/s}^2$ . What is the coefficient of friction between the toboggan and the snow?
- A. 0.012  
 B. 0.054  
 C. 0.22  
 D. 0.53
6. Which of the following describes kinetic energy and momentum before and after a perfectly elastic collision?

	KINETIC ENERGY	MOMENTUM
A.	Not Conserved	Not Conserved
B.	Not Conserved	Conserved
C.	Conserved	Not Conserved
D.	Conserved	Conserved

7. The 2.0 kg head of an axe strikes a tree horizontally at 40 m/s. The blade penetrates 0.040 m into the tree. What is the average force exerted by the blade on this tree?
- A.  $2.0 \times 10^1 \text{ N}$   
 B.  $2.0 \times 10^3 \text{ N}$   
 C.  $2.0 \times 10^4 \text{ N}$   
 D.  $4.0 \times 10^4 \text{ N}$

**OVER**

8. A 0.30 kg ball rolls off a horizontal surface as shown in the diagram. What is the magnitude of the impulse given to the ball by gravity during the 0.90 s it takes the ball to fall to the ground?

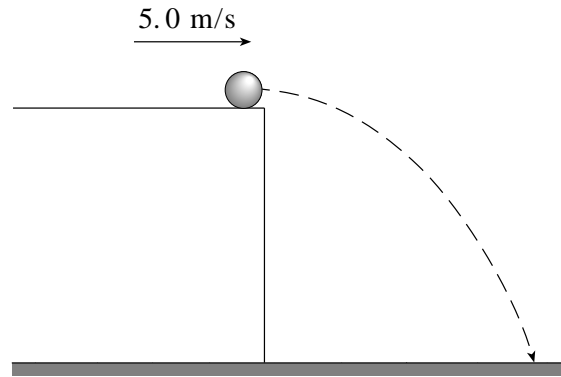

- A. 1.5 N·s
  - B. 2.6 N·s
  - C. 3.0 N·s
  - D. 4.1 N·s
9. A uniform ladder leans against a frictionless wall as shown.

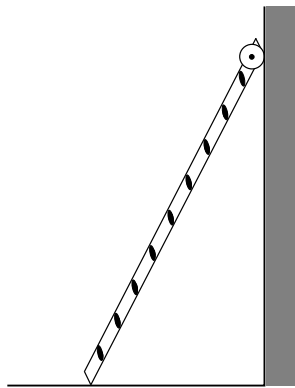

Which of the following diagrams **best** shows the forces acting on the ladder?

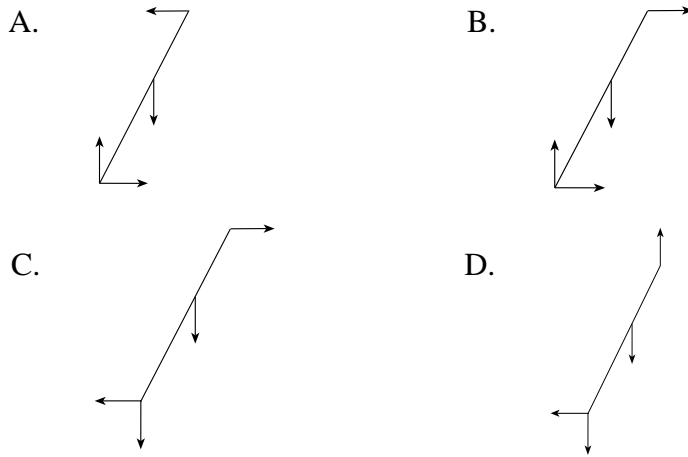

10. A 220 N bag of potatoes is suspended from a rope as shown in the diagram. A person pulls horizontally on the bag with a force of 80 N.

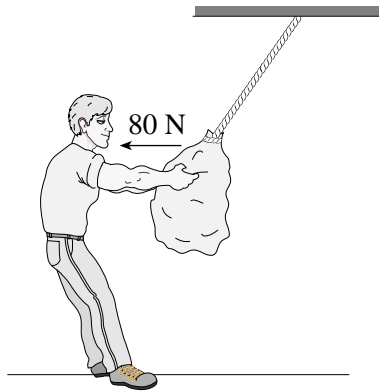

What is the tension in the rope?

- A.  $1.4 \times 10^2$  N  
 B.  $2.2 \times 10^2$  N  
 C.  $2.3 \times 10^2$  N  
 D.  $3.0 \times 10^2$  N
11. The shaded area shown in the diagram represents

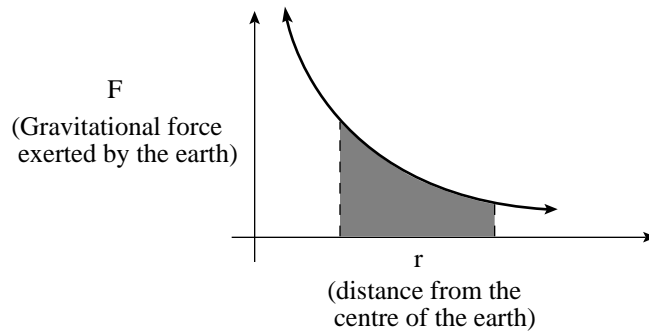

- A. the gravitational field strength near the earth.

- B. the escape velocity from the surface of the earth.
  - C. the centripetal acceleration of an object orbiting the earth.
  - D. the work required to move an object in the earth's gravitational field.
12. What is the magnitude of the centripetal acceleration of the earth as it orbits the sun?
- A.  $3.4 \times 10^{-18} \text{ m/s}^2$
  - B.  $1.8 \times 10^{-8} \text{ m/s}^2$
  - C.  $5.9 \times 10^{-3} \text{ m/s}^2$
  - D.  $9.8 \text{ m/s}^2$
13. A certain planet with a radius of  $7.0 \times 10^7 \text{ m}$  has an escape velocity of  $6.0 \times 10^4 \text{ m/s}$ . What is the mass of this planet?
- A.  $6.6 \times 10^{25} \text{ kg}$
  - B.  $1.9 \times 10^{27} \text{ kg}$
  - C.  $3.8 \times 10^{27} \text{ kg}$
  - D.  $1.3 \times 10^{35} \text{ kg}$
14. Mars orbits the sun at 1.52 times Earth's orbital radius. What is the orbital period of Mars in Earth years?
- A. 1.23 years
  - B. 1.52 years
  - C. 1.87 years
  - D. 2.31 years
15. A space shuttle orbits the earth at an altitude where the acceleration due to gravity is  $8.70 \text{ m/s}^2$ . What is the shuttle's speed at this altitude?
- A.  $2.65 \times 10^3 \text{ m/s}$
  - B.  $7.45 \times 10^3 \text{ m/s}$
  - C.  $7.68 \times 10^3 \text{ m/s}$
  - D.  $7.91 \times 10^3 \text{ m/s}$
16. Which of the following gives correct units for electric field strength?
- A. V

- B. C
- C. N/m
- D. V/m

17. A 6.0 V battery is connected through a switch to a 3.0 Ω resistor as shown below.

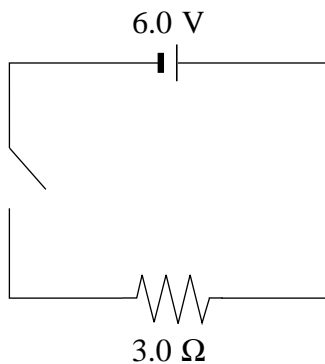

What total charge flows through the resistor if the switch is closed for 40 s ?

- A.  $2.0 \times 10^{-9}$  C  
 B. 2.0 C  
 C. 80 C  
 D. 480 C
18. Electric charges are arranged as shown in the diagram below.

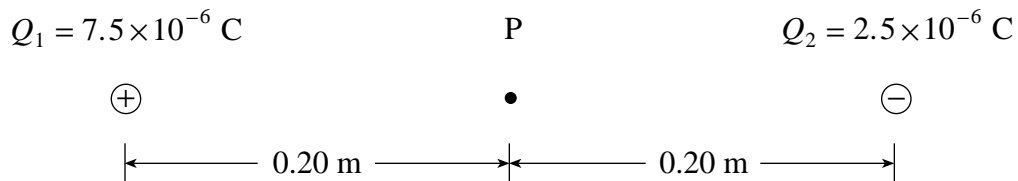

What is the electric field (magnitude and direction) at point P, midway between the charges?

	MAGNITUDE OF ELECTRIC FIELD (N/C)	DIRECTION OF ELECTRIC FIELD
A.	$1.1 \times 10^6$	Left
B.	$1.1 \times 10^6$	Right
C.	$2.3 \times 10^6$	Left
D.	$2.3 \times 10^6$	Right

19. What is the final speed of an electron accelerated from rest through a potential difference of 750 V ?
- A.  $3.8 \times 10^5$  m/s  
 B.  $8.1 \times 10^6$  m/s  
 C.  $1.6 \times 10^7$  m/s



D.  $2.6 \times 10^{14}$  m/s

20. Which of the following diagrams shows meters correctly placed to measure the circuit current and the terminal voltage of the battery?

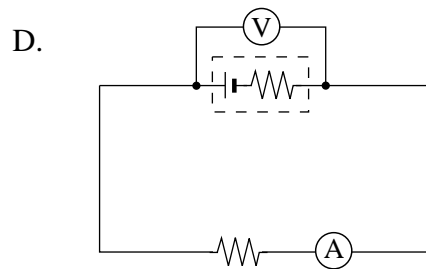
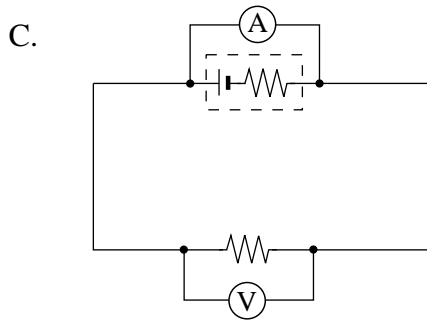
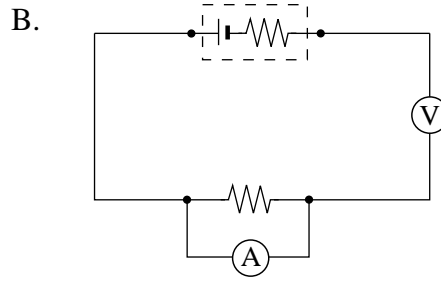
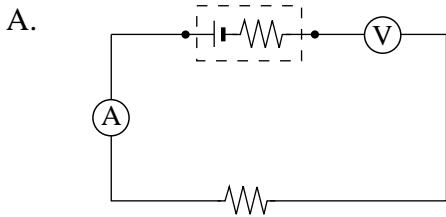

21. What is the terminal voltage of the cell in the circuit shown in the diagram below?

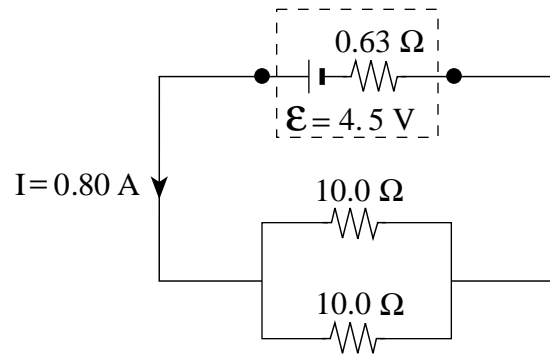

- A. 0.50 V
- B. 3.5 V
- C. 4.0 V
- D. 4.5 V

22. What is the power dissipated in resistor  $R_1$  in the circuit shown in the diagram below?

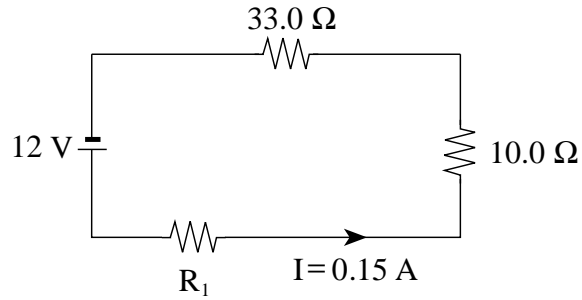

- A. 0.83 W
- B. 0.97 W
- C. 1.8 W
- D. 2.8 W

23. The diagram below shows part of an electrical circuit.

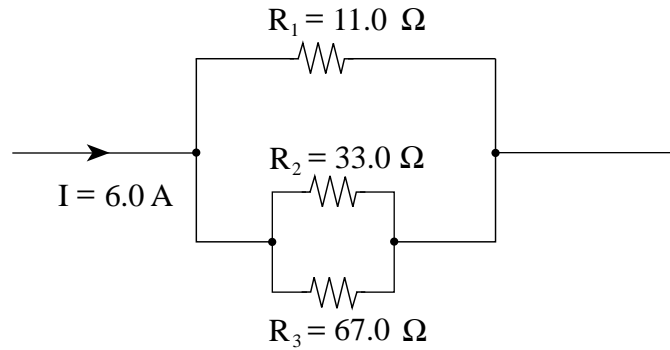

What is the current through resistor  $R_1$ ?

- A. 2.0 A
- B. 3.0 A
- C. 4.0 A
- D. 6.0 A

24. In the diagram below, what is the direction of the magnetic field at point P due to the bar magnet?

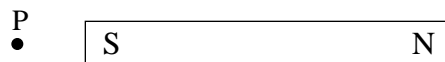

- A. up the page
- B. down the page
- C. towards the left
- D. towards the right

25. An ion with a charge of  $1.6 \times 10^{-19} \text{ C}$  enters a  $0.075 \text{ T}$  magnetic field. If the ion follows a circular path of radius  $0.083 \text{ m}$ , what is the momentum of the ion?
- A.  $2.7 \times 10^{-26} \text{ kg} \cdot \text{m/s}$   
 B.  $1.0 \times 10^{-21} \text{ kg} \cdot \text{m/s}$   
 C.  $1.7 \times 10^{-12} \text{ kg} \cdot \text{m/s}$   
 D.  $5.2 \times 10^{-4} \text{ kg} \cdot \text{m/s}$
26. A long straight wire is carrying a  $70 \text{ A}$  current. What is the magnitude of the magnetic field due to this current at a point  $0.15 \text{ m}$  from the wire?
- A.  $8.8 \times 10^{-5} \text{ T}$   
 B.  $9.3 \times 10^{-5} \text{ T}$   
 C.  $5.9 \times 10^{-4} \text{ T}$   
 D.  $6.2 \times 10^{-4} \text{ T}$
27. Which of the following describes a possible step-up transformer?

	PRIMARY		SECONDARY	
	$V_p$	$N_p$	$V_s$	$N_s$
A.	120 V	500	240 V	250
B.	120 V	500	60 V	250
C.	120 V	500	60 V	1 000
D.	120 V	500	240 V	1 000

28. A 525-turn solenoid has a diameter of  $0.050 \text{ m}$  and a length of  $0.20 \text{ m}$ . What current is needed to produce a  $0.025 \text{ T}$  field inside the solenoid?
- A.  $0.38 \text{ A}$   
 B.  $1.9 \text{ A}$   
 C.  $3.8 \text{ A}$   
 D.  $7.6 \text{ A}$

**OVER**

29. The flux through a 240 turn coil changes by  $4.0 \times 10^{-2}$  Wb in 0.20 s. What is the magnitude of the average emf induced in the coil during this time?
- A. 1.9 V  
 B. 9.6 V  
 C. 24 V  
 D. 48 V
30. Two solenoids  $S_1$  and  $S_2$  are placed close together as shown in the diagram below.

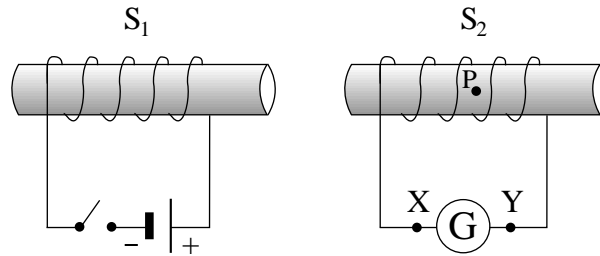

Immediately after the switch is closed, what is the direction of current flow through galvanometer  $G$  and what is the direction of the magnetic field produced by this current at position  $P$  inside solenoid  $S_2$ ?

	DIRECTION OF CURRENT THROUGH THE GALVANOMETER	DIRECTION OF MAGNETIC FIELD AT P
A.	From X to Y	Left
B.	From X to Y	Right
C.	From Y to X	Left
D.	From Y to X	Right

**This is the end of the multiple-choice section.  
 Answer the remaining questions directly in this examination booklet.**



## PART B: WRITTEN RESPONSE

Value: 48 marks

Suggested Time: 48 minutes

### INSTRUCTIONS:

1. Rough-work space has been incorporated into the space allowed for answering each written-response question. You may not need all of the space provided to answer each question.
2.
  - a) Final answers must include appropriate **units**.
  - b) Marks will not be deducted for answers expressed to **two** or **three** significant figures.
  - c) In this examination the zero in a number such as 30 shall be considered to be a significant zero.
3. You are expected to communicate your knowledge and understanding of physics principles in a clear and logical manner. If you are unable to determine the value of a quantity required in order to proceed, you may assume a reasonable value and continue toward the solution. Partial marks will be awarded for steps and assumptions leading to a solution. Such a solution, however, may not be eligible for full marks.

**Full marks will NOT be given for the final answer only.**

1. A projectile is launched over level ground at  $85 \text{ m/s}$ ,  $25^\circ$  above the horizontal. Air resistance may be ignored.
- a) Calculate the range (horizontal distance) of the projectile. **(5 marks)**

- b) Using principles of physics, comment on the horizontal and vertical components of the projectile's velocity and acceleration during the flight. **(4 marks)**

---

---

---

---

---

---

---

---

---

---



ANSWER:	Score for Question 1:
a) range: _____	1. _____ (9)

2. Two steel pucks collide as shown in the diagram below.

BEFORE COLLISION

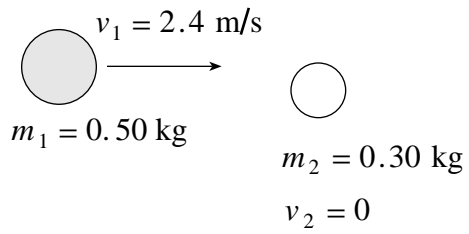

AFTER COLLISION

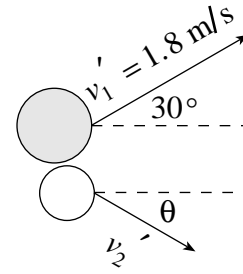

Determine the speed and direction (angle  $\theta$ ) of the 0.30 kg puck after the collision. **(7 marks)**



ANSWER:	Score for Question 2:
speed: _____	2. _____
angle $\theta$ : _____	(7)

3. A uniform 15 kg beam of length 4.0 m is supported against a wall as shown in the diagram. A 25 kg object is suspended 3.0 m from the hinge P.

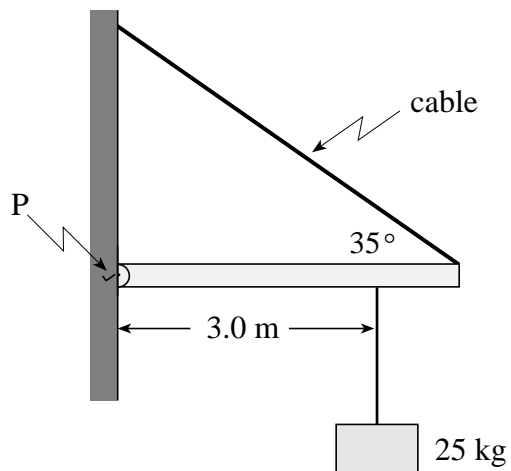

- a) What is the tension in the support cable?

**(5 marks)**

- b) What is the magnitude of the horizontal component of the reaction force of the wall on the beam at the hinge P? **(2 marks)**

ANSWER:	Score for Question 3:
a) tension: _____	3. _____
b) horizontal component: _____	(7)

4. The moon Deimos orbits the planet Mars at an orbital radius of  $2.34 \times 10^7$  m with an orbital period of  $1.08 \times 10^5$  s. What is the mass of Mars? **(7 marks)**





<p>ANSWER:</p> <p>mass: _____</p>	<p>Score for Question 4:</p> <p>4. _____ (7)</p>
-----------------------------------	--

5. The diagram shows a small sphere of mass  $1.5 \times 10^{-14}$  kg held in equilibrium between two parallel plates by electrostatic and gravitational forces.

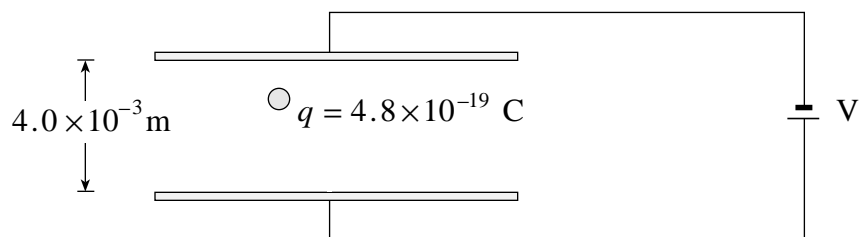

If the plates are  $4.0 \times 10^{-3}$  m apart and the sphere carries a charge of magnitude  $4.8 \times 10^{-19}$  C, what is the potential difference  $V$  between the plates? **(7 marks)**



ANSWER:	Score for Question 5:
potential difference: _____	5. _____ (7)

6. The diagram below shows a 650-turn solenoid carrying a 4.0 A current.

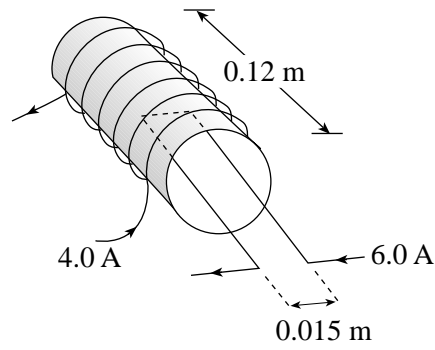

What is the magnitude of the magnetic force on the 0.015 m segment of wire carrying a 6.0 A current inside the solenoid as shown? **(7 marks)**



<p>ANSWER:</p> <p>magnetic force: _____</p>	<p>Score for Question 6:</p> <p>6. _____ (7)</p>
---	--



7. You are given a voltmeter, an ammeter, connecting wires, a battery, and a resistor of unknown resistance. Describe a method you could use with this apparatus to determine the unknown resistance. (A circuit diagram may be used as **part** of your answer.) **(4 marks)**

---

---

---

---

---

---

---

---

Score for Question 7:  7. _____ (4)
---

**This is the end of the written-response section.**

## PART C: ELECTED TOPICS

Value: 12 marks

Suggested Time: 12 minutes

### INSTRUCTIONS

1. Choose **only one** section from the three sections in this part of the examination.

SECTION I: Quantum Mechanics (p. 26 to 28)

**or**

SECTION II: Fluid Theory (p. 30 to 32)

**or**

SECTION III: AC Circuitry and Electronics (p. 34 to 36)

2. If you answer questions in more than one section, only the answers in the first section chosen will be marked.
3. Answer **all** of the questions in the section that you choose. **Write your answers in the space provided in this booklet.**
4. Rough-work space has been incorporated into the space allowed for answering each question. You may not need all of the space provided to answer each question.
5.
  - a) Final answers must include appropriate **units**.
  - b) Marks will not be deducted for answers expressed to **two** or **three** significant figures.
  - c) In this examination the zero in a number such as 30 shall be considered to be a significant zero.
6. Since partial marks will be awarded for a partial solution, it is important that you provide a clear indication of the steps leading to your answer.

**Full marks will NOT be given for the final answer only.**

**I have selected SECTION \_\_\_\_\_.**

**OVER**

## SECTION I: Quantum Mechanics

1. A singly ionized helium atom contains two protons in its nucleus. What is the energy of an electron in the second excited state ( $n = 3$ ) of this ion? **(3 marks)**

ANSWER:	Score for Question 1:
energy: _____	8. _____ (3)

**SECTION I: Continued**

2. A laser emits light of wavelength  $6.3 \times 10^{-7}$  m.

a) What is the energy of each photon emitted?

**(2 marks)**

b) The total power output of the laser is 0.50 W. How many photons are emitted in a 3.0 s interval?

**(2 marks)**

ANSWER:	Score for Question 2:
a) energy: _____	9. _____
b) number of photons: _____	(4)

**SECTION I: Continued**

3. Light of frequency  $7.9 \times 10^{14}$  Hz emits photoelectrons from a metal surface with a maximum speed of  $6.7 \times 10^5$  m/s. What frequency of light is necessary to release photoelectrons from this same surface with twice this speed? **(5 marks)**

ANSWER:  frequency: _____	Score for Question 3:  10. _____ (5)
---------------------------------	--



**END OF SECTION I: Quantum Mechanics**

**THIS PAGE INTENTIONALLY BLANK**

## SECTION II: Fluid Theory

1. A 45 kg ballet dancer briefly balances on her toe. Calculate the pressure applied on the floor by the dancer's toe if the toe has an area of  $2.2 \times 10^{-4} \text{ m}^2$ . **(3 marks)**

ANSWER:	Score for Question 1:
pressure: _____	11. _____ (3)

**SECTION II: Continued**

2. The absolute pressure of a gas in a rigid container at  $20^{\circ}\text{C}$  is  $4.5 \times 10^5$  Pa. If the temperature increases to  $40^{\circ}\text{C}$ , what is the pressure of the gas? **(4 marks)**

ANSWER:	Score for Question 2:
pressure: _____	12. _____ (4)

**SECTION II: Continued**

3. Fresh water flows through the pipe shown below. The pressure in Area 1 is  $P_1 = 1.6 \times 10^5$  Pa and in Area 2 is  $P_2 = 1.2 \times 10^5$  Pa.

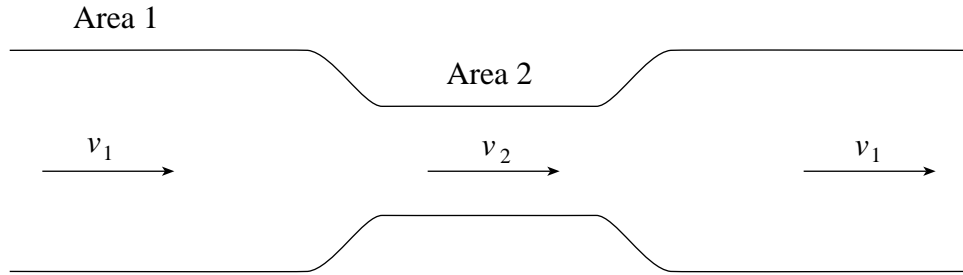

If the speed of the water in Area 1 is  $v_1 = 3.0$  m/s, what is the speed of the water  $v_2$  in Area 2?  
**(5 marks)**

ANSWER:	Score for Question 3:
speed: _____	13. _____ (5)

**END OF SECTION II: Fluid Theory**



**THIS PAGE INTENTIONALLY BLANK**

### SECTION III: AC Circuitry and Electronics

1. The diagram below shows a circuit in which switch S has been closed for a long time. When the switch is opened, it takes 22 s for the voltage across the capacitor to drop to 37 V. (3 marks)

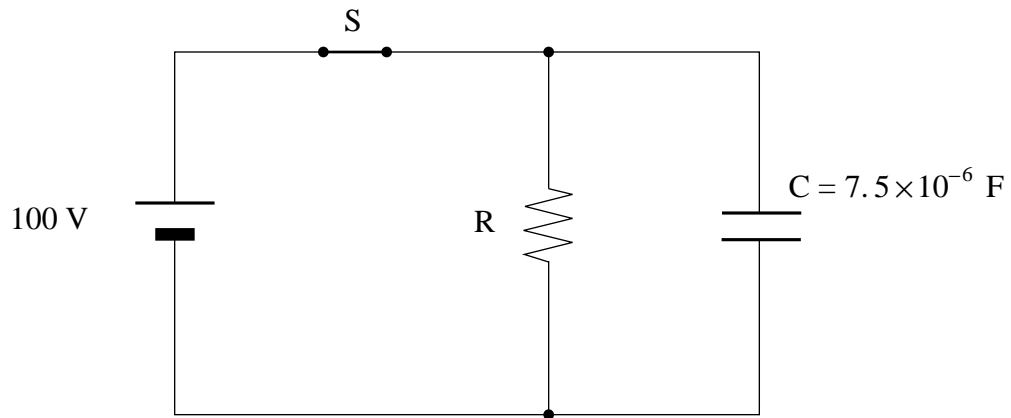

What is the value of resistor R?

ANSWER:	Score for Question 1:
resistor R: _____	14. _____ (3)

**SECTION III: Continued**

2. What is the equivalent capacitance of the circuit below?

**(4 marks)**

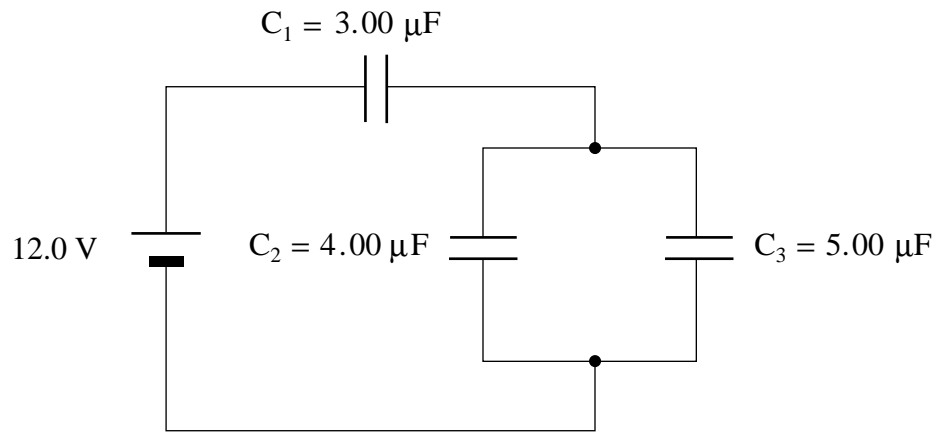

ANSWER:	Score for Question 2:
capacitance: _____	15. _____ (4)

**SECTION III: Continued**

3. What is the impedance of the following circuit?

**(5 marks)**

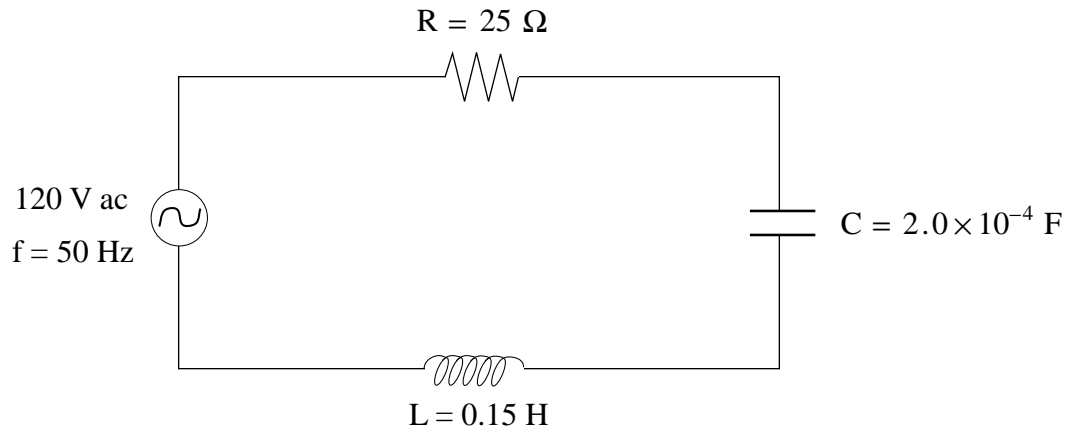

ANSWER:

impedance: \_\_\_\_\_

Score for  
Question 3:

16. \_\_\_\_\_  
(5)

**END OF SECTION III: AC Circuitry and Electronics**

**END OF EXAMINATION**





## DATA TABLE

Gravitational constant .....	$G = 6.67 \times 10^{-11} \text{ N} \cdot \text{m}^2/\text{kg}^2$
Acceleration due to gravity at the surface of Earth (for the purposes of this examination) .....	$g = 9.80 \text{ m/s}^2$
<b>Earth</b>	
radius .....	$= 6.38 \times 10^6 \text{ m}$
radius of orbit about Sun .....	$= 1.50 \times 10^{11} \text{ m}$
period of rotation .....	$= 8.61 \times 10^4 \text{ s}$
period of revolution about Sun .....	$= 3.16 \times 10^7 \text{ s}$
mass .....	$= 5.98 \times 10^{24} \text{ kg}$
<b>Moon</b>	
radius .....	$= 1.74 \times 10^6 \text{ m}$
radius of orbit about Earth .....	$= 3.84 \times 10^8 \text{ m}$
period of rotation .....	$= 2.36 \times 10^6 \text{ s}$
period of revolution about Earth .....	$= 2.36 \times 10^6 \text{ s}$
mass .....	$= 7.35 \times 10^{22} \text{ kg}$
<b>Sun</b>	
mass .....	$= 1.98 \times 10^{30} \text{ kg}$
Constant in Coulomb's Law .....	$k = 9.00 \times 10^9 \text{ N} \cdot \text{m}^2/\text{C}^2$
Elementary charge .....	$e = 1.60 \times 10^{-19} \text{ C}$
Mass of electron .....	$m_e = 9.11 \times 10^{-31} \text{ kg}$
Mass of proton .....	$m_p = 1.67 \times 10^{-27} \text{ kg}$
Mass of neutron .....	$m_n = 1.68 \times 10^{-27} \text{ kg}$
Permeability of free space .....	$\mu_o = 4\pi \times 10^{-7} \text{ T} \cdot \text{m/A}$
Planck's constant .....	$h = 6.63 \times 10^{-34} \text{ J} \cdot \text{s}$ $h = 4.14 \times 10^{-15} \text{ eV} \cdot \text{s}$
Speed of light .....	$c = 3.00 \times 10^8 \text{ m/s}$
Rydberg's constant .....	$R = 1.097 \times 10^7 \text{ m}^{-1}$
Unified atomic mass unit .....	$u = 1.66 \times 10^{-27} \text{ kg}$
Boltzmann's constant .....	$k = 1.38 \times 10^{-23} \text{ J/K}$
Gas constant .....	$R = 8.31 \text{ J/mol} \cdot \text{K}$
Density of water .....	$= 1.00 \times 10^3 \text{ kg/m}^3$
Density of air .....	$= 1.29 \text{ kg/m}^3$
Standard atmospheric pressure .....	$= 1.01 \times 10^5 \text{ Pa}$
Volume of one mole of gas at STP .....	$= 22.4 \text{ L} (2.24 \times 10^{-2} \text{ m}^3)$
Avogadro's number .....	$N = 6.02 \times 10^{23} \text{ particles/mol}$
Absolute zero .....	$= -273^\circ \text{C}$

**You may detach this page for convenient reference.  
Exercise care when tearing along perforations.**

## TRIGONOMETRIC AND OTHER EQUATIONS

### For Right-angled Triangles:

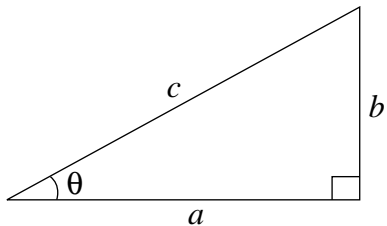

$$a^2 + b^2 = c^2$$

$$\sin \theta = \frac{b}{c} \quad \cos \theta = \frac{a}{c} \quad \tan \theta = \frac{b}{a}$$

$$\text{area} = \frac{1}{2} ab$$

### For All Triangles:

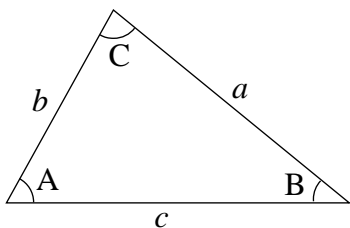

$$\text{area} = \frac{1}{2} \text{base} \times \text{height}$$

$$\sin 2A = 2 \sin A \cos A$$

$$\text{Sine Law: } \frac{\sin A}{a} = \frac{\sin B}{b} = \frac{\sin C}{c}$$

$$\text{Cosine Law: } c^2 = a^2 + b^2 - 2ab \cos C$$

### Circle:

$$\text{Circumference} = 2\pi r$$

$$\text{Area} = \pi r^2$$

### Sphere:

$$\text{Surface area} = 4\pi r^2$$

$$\text{Volume} = \frac{4}{3}\pi r^3$$

### Quadratic Equation:

$$\text{If } ax^2 + bx + c = 0, \text{ then } x = \frac{-b \pm \sqrt{b^2 - 4ac}}{2a}$$



## EQUATIONS

**Note: Vector quantities have not been indicated.**

### 1. Kinematics: (for constant acceleration)

$$v = v_0 + at \qquad v_{av} = \frac{v + v_0}{2} \qquad v^2 = v_0^2 + 2ad$$
$$d = v_0t + \frac{1}{2}at^2$$

### 2. Dynamics:

$$F_f = \mu F_N \qquad F_{net} = ma$$

### 3. Mechanical Energy and Momentum:

$$W = Fd \qquad E_p = mgh \qquad E_k = \frac{1}{2}mv^2$$
$$P = \frac{W}{t} \qquad p = mv \qquad \Delta p = F_{net}\Delta t$$

### 4. Equilibrium:

$$\tau = Fd$$

### 5. Circular Motion and Gravitation:

$$a_c = \frac{v^2}{r} = \frac{4\pi^2 r}{T^2} \qquad F = G \frac{m_1 m_2}{r^2}$$
$$E_p = -G \frac{m_1 m_2}{r} \qquad r^3 \propto T^2$$

### 6. Electrostatics:

$$F = k \frac{Q_1 Q_2}{r^2} \qquad E = \frac{V}{d} \qquad V = \frac{kQ}{r}$$
$$E_p = k \frac{Q_1 Q_2}{r} \qquad F = QE \qquad V = \frac{\Delta E_p}{Q}$$

### 7. Circuitry:

$$Q = It \qquad V = IR \qquad P = VI$$

You may detach this page for convenient reference.  
Exercise care when tearing along perforations.

## EQUATIONS (continued)

### 8. Electromagnetism:

$$\begin{array}{lll}
 F = IlB & B = \frac{\mu_0 I}{2\pi d} & \tau = NIAB \\
 F = QvB & B = \mu_0 n I \left( \text{where } n = \frac{N}{l} \right) & \Phi = BA \\
 \mathcal{E} = -N \frac{\Delta\Phi}{\Delta t} & \mathcal{E} = Blv & \frac{V_s}{V_p} = \frac{N_s}{N_p}
 \end{array}$$

### 9. Quantum Mechanics: (Section I)

$$\begin{array}{lll}
 E = hf & c = f\lambda & E_n = (-13.6eV) \frac{Z^2}{n^2} \\
 E_{k_{\max}} = hf - W_0 & \lambda = \frac{h}{p} &
 \end{array}$$

### 10. Fluid Theory: (Section II)

$$\begin{array}{lll}
 \rho = \frac{m}{V} & PV = NkT & PV = \frac{1}{3} Nmv^2 \\
 F = \rho Vg & P = \frac{F}{A} & P = P_G + P_a \\
 PV = nRT & P + \frac{1}{2}\rho v^2 + \rho gh = \text{constant} & E_k = \frac{3}{2} kT \\
 & Av = \text{constant} &
 \end{array}$$

### 11. AC Circuits and Electronics: (Section III)

$$\begin{array}{lll}
 Q = CV & E_p = \frac{1}{2} CV^2 & \tau = RC \\
 X_C = \frac{1}{2\pi fC} & Z = \sqrt{R^2 + (X_L - X_C)^2} & X_L = 2\pi fL \\
 f_0 = \frac{1}{2\pi\sqrt{LC}} & \beta \text{ (current gain)} = \frac{\Delta I_C}{\Delta I_B} & A_f = \frac{A}{1 - \beta A} \\
 & & \text{(where } \beta = \text{ feedback ratio)}
 \end{array}$$



**ROUGH WORK FOR MULTIPLE-CHOICE**

# ROUGH WORK FOR MULTIPLE-CHOICE



