

**AUGUST 1996**

## **PROVINCIAL EXAMINATION**

---

**MINISTRY OF EDUCATION, SKILLS AND TRAINING**

# **PHYSICS 12**

### **GENERAL INSTRUCTIONS**

1. Insert the stickers with your Student I.D. Number (PEN) in the allotted spaces above. **Under no circumstance is your name or identification, other than your Student I.D. Number, to appear on this paper.**
2. Take the separate Answer Sheet and follow the directions on its front page.
3. Be sure you have an HB pencil and an eraser for completing your Answer Sheet. Follow the directions on the Answer Sheet when answering multiple-choice questions.
4. For each of the written-response questions, write your answer in the space provided.
5. When instructed to open this booklet, **check the numbering of the pages** to ensure that they are numbered in sequence from page one to the last page, which is identified by

**END OF EXAMINATION**.

6. At the end of the examination, place your Answer Sheet inside the front cover of this booklet and return the booklet and your Answer Sheet to the supervisor.

**THIS PAGE INTENTIONALLY BLANK**

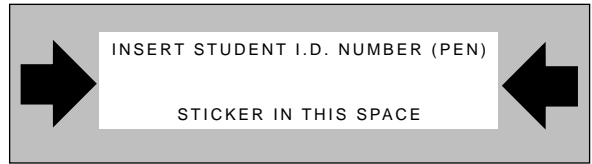

\_\_\_\_\_ - \_\_\_\_\_

**PHYSICS 12 AUGUST 1996 PROVINCIAL**

**Course Code = PH Examination Type = P**

1. \_\_\_\_\_  
(9)

5. \_\_\_\_\_  
(7)

2. \_\_\_\_\_  
(7)

6. \_\_\_\_\_  
(7)

3. \_\_\_\_\_  
(7)

7. \_\_\_\_\_  
(4)

4. \_\_\_\_\_  
(7)

Score **only one** of the following sections.

**Section I**

**Section II**

**Section III**

8. \_\_\_\_\_  
(3)

11. \_\_\_\_\_  
(3)

14. \_\_\_\_\_  
(3)

9. \_\_\_\_\_  
(4)

**or**

12. \_\_\_\_\_  
(4)

**or**

15. \_\_\_\_\_  
(4)

10. \_\_\_\_\_  
(5)

13. \_\_\_\_\_  
(5)

16. \_\_\_\_\_  
(5)

**THIS PAGE INTENTIONALLY BLANK**

## PHYSICS 12 PROVINCIAL EXAMINATION

	Value	Suggested Time
1. This examination consists of <b>three</b> parts:		
PART A: 30 multiple-choice questions worth two marks each	60	60
PART B: 7 written-response questions	48	48
PART C: Elected topics consisting of only written-response questions. Answer <b>only one</b> section.	12	12
	<b>Total: 120 marks</b>	<b>120 minutes</b>

- The last **three** pages inside the back cover contain the **Data Table, Trigonometric and Other Equations, Equations, and Rough Work for Multiple-Choice**. These pages may be detached for convenient reference prior to writing this examination.
- Rough-work space has been incorporated into the space allowed for answering each written-response question. You may not need all of the space provided to answer each question.
- An approved scientific calculator is essential for the examination. The calculator must be a hand-held device designed **only** for mathematical computations such as logarithmic and trigonometric functions. It **can be** programmable, but **must not** contain any graphing capabilities. You **must not** bring into the examination room any devices to support calculators such as manuals, printed or electronic cards, printers, memory expansion chips or cards, or keyboards.
- You are permitted to use rulers, compasses and protractors.
- Final answers must include appropriate **units**.
  - Marks will not be deducted for answers expressed to **two** or **three** significant figures.
  - In this examination the zero in a number such as 30 shall be considered to be a significant zero.
- You are expected to communicate your knowledge and understanding of physics principles in a clear and logical manner. Partial marks will be awarded for steps and assumptions leading to a solution. Full marks will **not** be awarded for providing **only** a final answer.

If you are unable to determine the value of a quantity required in order to proceed, you may assume a reasonable value and continue toward the solution. Such a solution, however, may not be eligible for full marks.
- You have **two hours** to complete this examination.

**THIS PAGE INTENTIONALLY BLANK**

**PART A: MULTIPLE CHOICE**

**Value: 60 marks (2 marks per question)**





**Suggested Time: 60 minutes**

**INSTRUCTIONS:** For each question, select the **best** answer and record your choice on the Answer Sheet provided. Using an HB pencil, completely fill in the circle that has the letter corresponding to your answer.

1. Which set of quantities contains no vectors?

- A. mass, speed, time
- B. force, speed, velocity
- C. acceleration, force, time
- D. acceleration, mass, velocity

2. An airplane which was flying eastward is later flying southward at the same speed. Which vector shows the airplane's **change** in velocity?

- A.  B.  
- C.  D. 

3. At  $t = 0$  s a ball rolls off the edge of a vertical cliff. At  $t = 2.0$  s the ball is 6.0 m from the cliff as shown.

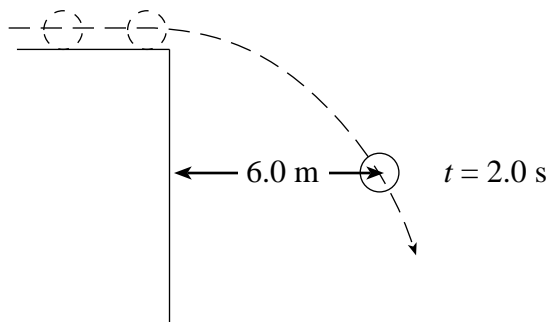

How far is the ball from the cliff at  $t = 4.0$  s?

- A. 6.0 m
- B. 9.0 m
- C. 12 m
- D. 24 m

4. A 4.0 kg block has a speed of 9.0 m/s at X.

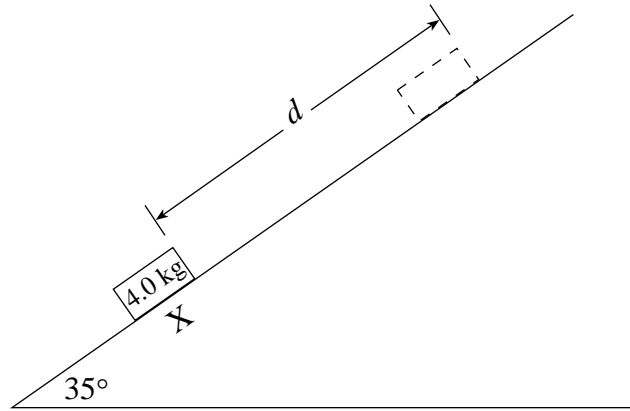

What is the maximum distance,  $d$ , travelled by the block? Ignore friction.

- A. 0.92 m
  - B. 1.6 m
  - C. 4.1 m
  - D. 7.2 m
5. The tension in the string shown is 12 N. Find the acceleration of mass  $m_1$ .

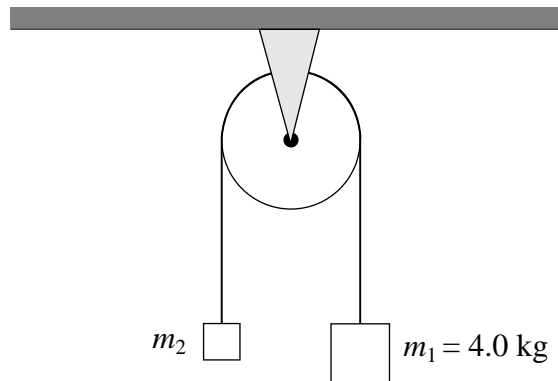

- A.  $3.0 \text{ m/s}^2$
  - B.  $6.4 \text{ m/s}^2$
  - C.  $6.8 \text{ m/s}^2$
  - D.  $13 \text{ m/s}^2$
6. Impulse is defined as
- A. total energy.
  - B. total momentum.
  - C. a change in energy.
  - D. a change in momentum.



7. Calculate the minimum power of a cyclist who can increase his kinetic energy from 480 J to 2 430 J by travelling 26 m in 4.0 s.
- A. 75 W  
 B.  $3.6 \times 10^2$  W  
 C.  $4.9 \times 10^2$  W  
 D.  $7.3 \times 10^2$  W

8. A small explosive device sliding to the right breaks into two pieces. The momentum of fragment 1 after the explosion is 23 kg · m/s.

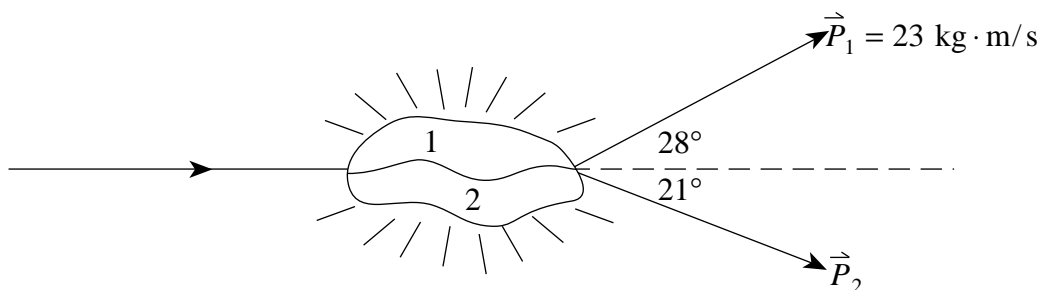

What is the momentum of fragment 2 after the explosion?

- A. 22 kg · m/s  
 B. 23 kg · m/s  
 C. 30 kg · m/s  
 D. 32 kg · m/s
9. Which set of conditions is true in all inelastic collisions?

	MOMENTUM	KINETIC ENERGY	TOTAL ENERGY
A.	Conserved	Conserved	Conserved
B.	Conserved	Not conserved	Conserved
C.	Not conserved	Not conserved	Conserved
D.	Not conserved	Conserved	Not conserved

10. An object moves at a constant speed along a circular path as shown.

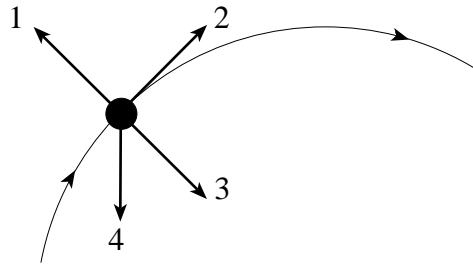

Which vector **best** represents the centripetal acceleration of the object at this point?

- A. 1
- B. 2
- C. 3
- D. 4

11. A 1.2 kg mass on the end of a string is rotated in a vertical circle of radius 0.85 m.

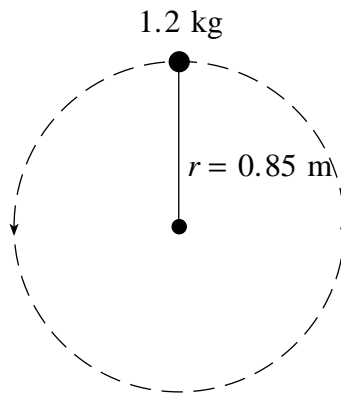

If the speed of the mass at the top of the circle is 3.6 m/s, what is the tension in the string at this location?

- A. 6.5 N
- B. 12 N
- C. 18 N
- D. 30 N

12. A certain planet has a mass of  $3.3 \times 10^{23}$  kg and a radius of  $2.6 \times 10^6$  m. What is the acceleration due to gravity on the surface of this planet?
- A.  $0.54 \text{ m/s}^2$
  - B.  $3.3 \text{ m/s}^2$
  - C.  $4.0 \text{ m/s}^2$
  - D.  $9.8 \text{ m/s}^2$
13. Relative to zero at infinity, what is the gravitational potential energy of a  $7.2 \times 10^2$  kg satellite that is at a distance of  $3.4 \times 10^7$  m from earth's centre?
- A.  $-2.4 \times 10^{11}$  J
  - B.  $-8.4 \times 10^9$  J
  - C.  $8.4 \times 10^9$  J
  - D.  $2.4 \times 10^{11}$  J
14. A person is on a horizontal rotating platform at a distance of 4.3 m from its centre. This person experiences a centripetal acceleration of  $5.6 \text{ m/s}^2$ . What centripetal acceleration is experienced by another person who is at a distance of 2.5 m from the centre of the platform?
- A.  $2.3 \text{ m/s}^2$
  - B.  $3.3 \text{ m/s}^2$
  - C.  $5.6 \text{ m/s}^2$
  - D.  $9.6 \text{ m/s}^2$
15. Which of the following is an equivalent unit for the volt?
- A.  $\frac{\text{C}}{\text{s}}$
  - B.  $\frac{\text{J}}{\text{C}}$
  - C.  $\frac{\text{N}}{\text{C}}$
  - D. J

16. A proton is accelerated from rest between parallel plates with a potential difference of  $3.0 \times 10^4$  V.

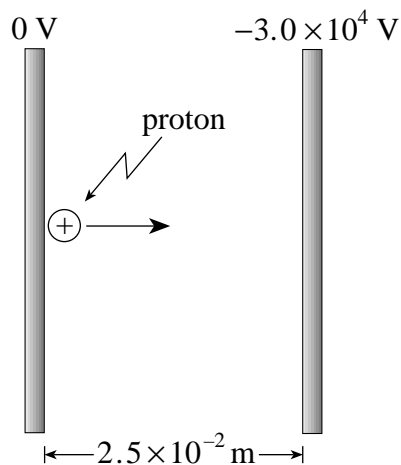

What is the maximum speed of the proton?

- A.  $1.3 \times 10^1$  m/s  
 B.  $3.8 \times 10^5$  m/s  
 C.  $2.4 \times 10^6$  m/s  
 D.  $1.5 \times 10^7$  m/s
17. What are the magnitude and direction of the electric force on the  $+2.0 \times 10^{-6}$  C charge shown below?

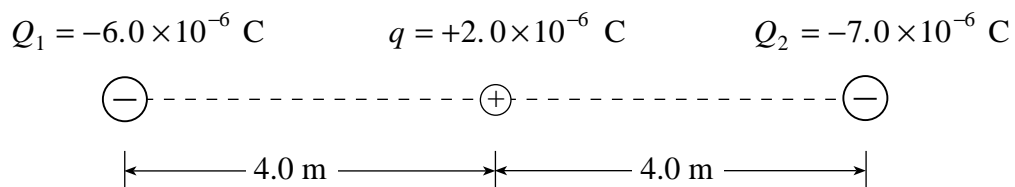

	MAGNITUDE OF FORCE	DIRECTION OF FORCE
A.	$1.1 \times 10^{-3}$ N	Left
B.	$1.1 \times 10^{-3}$ N	Right
C.	$1.5 \times 10^{-3}$ N	Left
D.	$1.5 \times 10^{-3}$ N	Right

18. What is the electric potential energy of an electron at a distance of  $5.3 \times 10^{-11}$  m from the proton in a hydrogen atom?
- A.  $-4.3 \times 10^{-18}$  J  
 B.  $-8.2 \times 10^{-8}$  J  
 C.  $-2.7 \times 10^1$  J  
 D.  $-5.1 \times 10^{11}$  J

19. Which of the following shows the correct placement of an ammeter and a voltmeter in the circuit?

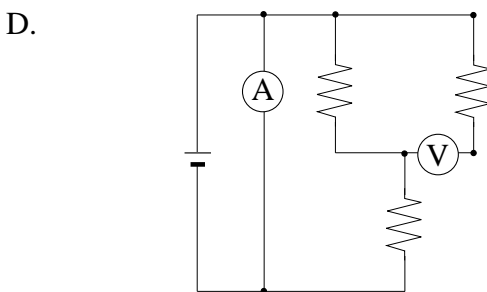
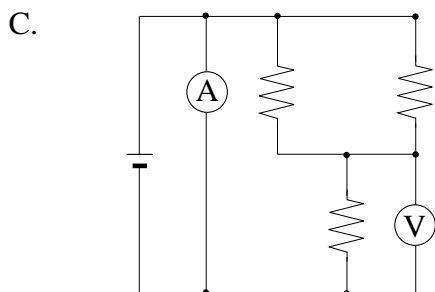
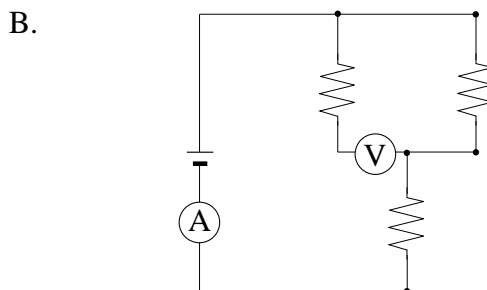
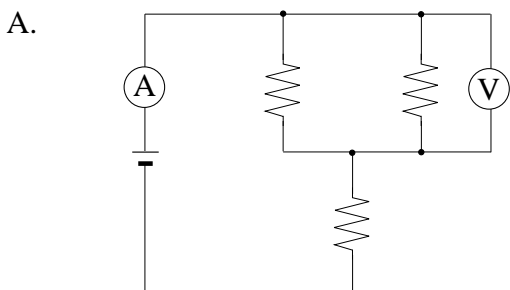

20. A 75 W bulb is connected across a 120 V source. While the bulb is lighted, what is the effective resistance of the bulb?
- A.  $0.62 \Omega$   
 B.  $1.6 \Omega$   
 C.  $47 \Omega$   
 D.  $190 \Omega$

21. The following circuit is a balanced potentiometer for cell  $\mathcal{E}_1 = 1.80 \text{ V}$  when it is connected at the  $0.70 \text{ m}$  position.

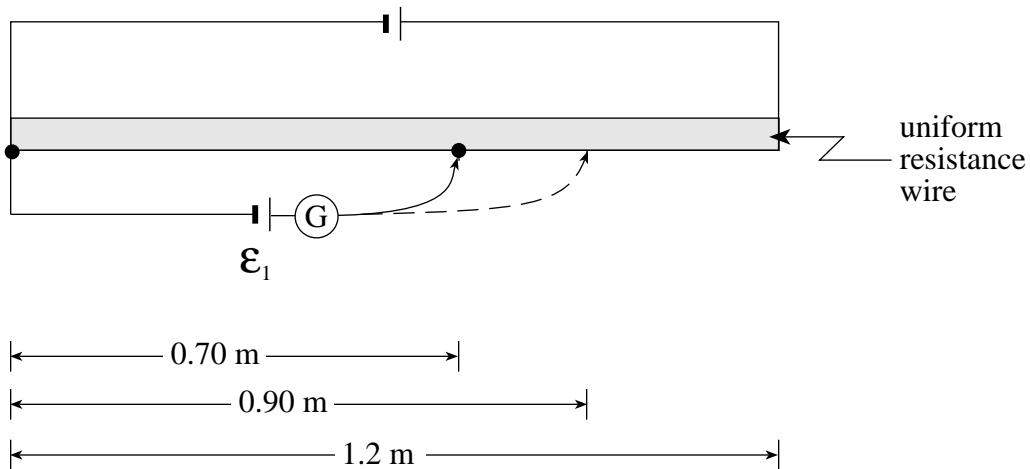

Balance is achieved with a new cell when the connection is moved to the  $0.90 \text{ m}$  position. What is the emf of the new cell?

- A.  $0.51 \text{ V}$   
 B.  $1.4 \text{ V}$   
 C.  $2.3 \text{ V}$   
 D.  $3.0 \text{ V}$
22. In the following circuit, what is the power dissipated by resistor  $R_1$ ?

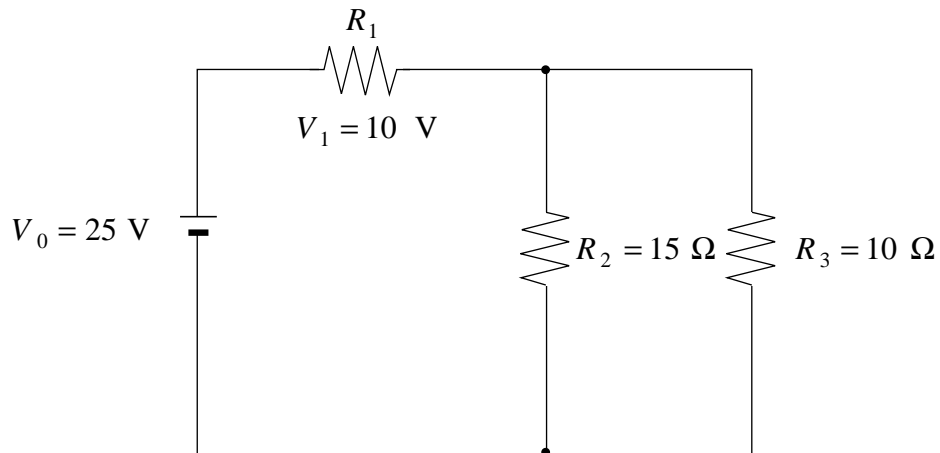

- A.  $10 \text{ W}$   
 B.  $15 \text{ W}$   
 C.  $25 \text{ W}$   
 D.  $42 \text{ W}$

23. In the circuit shown below, voltmeter readings are taken when switch **S** is closed and open.

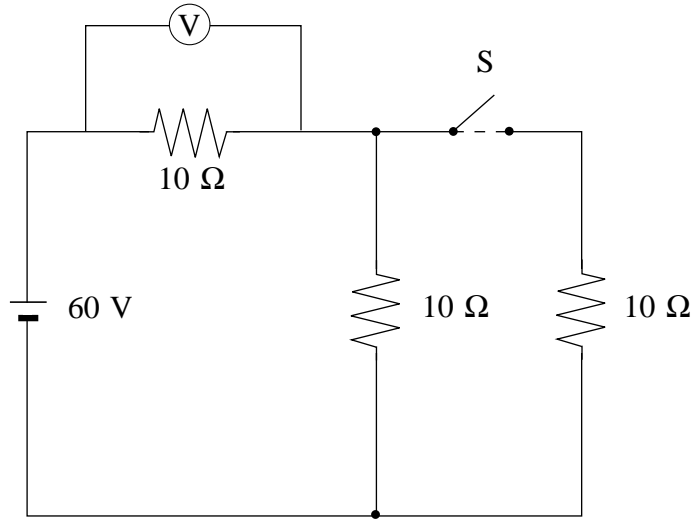

Which of the following is correct?

VOLTMETER READINGS	
SWITCH CLOSED	SWITCH OPEN
A. 20 V	30 V
B. 30 V	30 V
C. 40 V	20 V
D. 40 V	30 V

24. The magnetic field around a current-carrying wire is investigated with a compass.

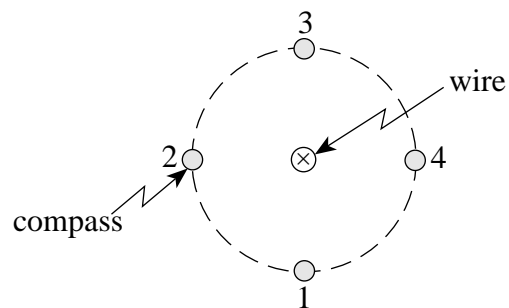

At which of the four positions shown in the diagram will the compass needle point towards the bottom of the page?

- A. 1
- B. 2
- C. 3
- D. 4

25. When a 15.0 A current flows through a 0.120 m long solenoid, the magnetic field along its centre is  $8.00 \times 10^{-2}$  T. How many turns make up this solenoid?
- A. 23
  - B. 162
  - C. 509
  - D. 4 240
26. A coil of wire has an area of  $2.5 \times 10^{-3}$  m<sup>2</sup>. What is the magnetic flux through this coil when its plane is perpendicular to a 0.75 T magnetic field?
- A. 0 Wb
  - B.  $1.9 \times 10^{-3}$  Wb
  - C.  $3.3 \times 10^{-3}$  Wb
  - D. 0.75 Wb
27. A dc motor has an armature resistance of 1.5  $\Omega$ . When running at full speed, the motor draws a current of 2.0 A from a 16 V source. What is the back emf at this speed?
- A. 0 V
  - B. 3 V
  - C. 13 V
  - D. 16 V
28. In order to induce an emf in a coil, the magnetic flux must be
- A. zero.
  - B. small.
  - C. large.
  - D. changing.



29. Charged particles **J** and **K** enter a magnetic field as show in the diagram below.

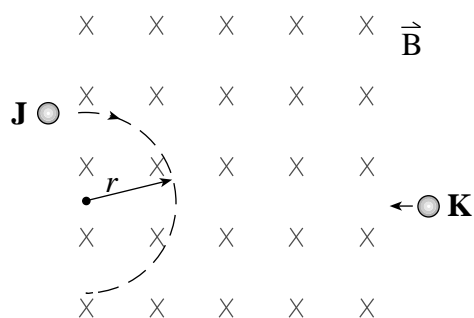

Particle **J** travels in a circular path of radius  $r$ . Particle **K** has twice the charge and half the momentum of particle **J**. How does the radius of particle **K**'s path compare to that of particle **J**?

- A.  $\frac{1}{4}r$
- B.  $r$
- C.  $2r$
- D.  $4r$

30. A transformer is used to reduce the house supply (120 V ac) to operate a small toy that requires 9.0 V ac at 0.240 A. Which of the following gives the primary current and possible values for primary and secondary windings?

	PRIMARY CURRENT	PRIMARY WINDINGS	SECONDARY WINDINGS
A.	0.018 A	720	54
B.	0.018 A	54	720
C.	3.2 A	720	54
D.	3.2 A	54	720

**This is the end of the multiple-choice section.  
Answer the remaining questions directly in this examination booklet.**

**THIS PAGE INTENTIONALLY BLANK**

## PART B: WRITTEN RESPONSE

Value: 48 marks

Suggested Time: 48 minutes

### INSTRUCTIONS:

1. Rough-work space has been incorporated into the space allowed for answering each written-response question. You may not need all of the space provided to answer each question.
2.
  - a) Final answers must include appropriate **units**.
  - b) Marks will not be deducted for answers expressed to **two** or **three** significant figures.
  - c) In this examination the zero in a number such as 30 shall be considered to be a significant zero.
3. You are expected to communicate your knowledge and understanding of physics principles in a clear and logical manner. If you are unable to determine the value of a quantity required in order to proceed, you may assume a reasonable value and continue toward the solution. Partial marks will be awarded for steps and assumptions leading to a solution. Such a solution, however, may not be eligible for full marks.

**Full marks will NOT be given for the final answer only.**

1. a) Amanda exerts a horizontal force of 180 N on a piece of rope causing two blocks of mass 20 kg and 40 kg to accelerate. Friction on the blocks is negligible. Find the tension force at X in the rope joining the two blocks together. **(5 marks)**

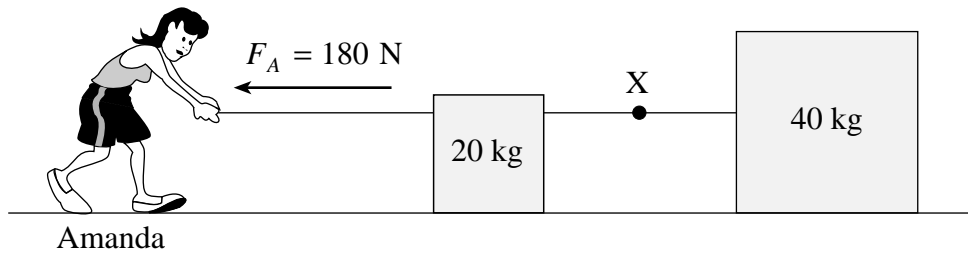

b) Bob exerts a force of equal magnitude in the opposite direction on an identical pair of blocks.

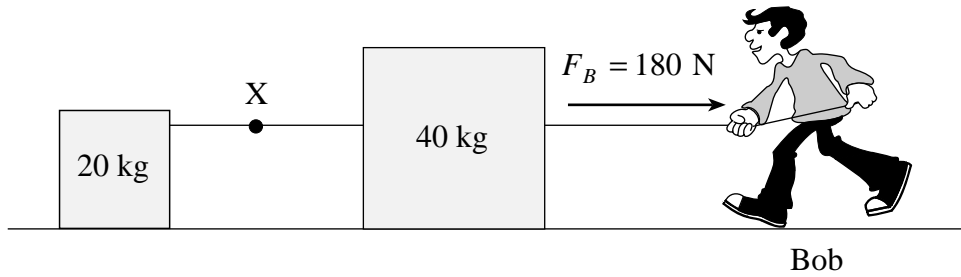

How does the tension force at **X** compare to the value in part a)? (Circle one.) **(1 mark)**

- i) The tension force is the same.
- ii) The tension force is greater than in a).
- iii) The tension force is smaller than in a).

c) Using principles of physics, explain your answer to part b). **(3 marks)**

---

---

---

---

---

---

---

---

ANSWER:	Score for Question 1:
a) tension force: _____	1. _____ (9)

2. A 24 kg rocket car is initially at rest on a frictionless horizontal surface. The engine is ignited and the graph below shows thrust force,  $F$ , versus distance travelled,  $d$ , for the rocket car. Find the rocket car's speed after it has travelled 200 m. **(7 marks)**

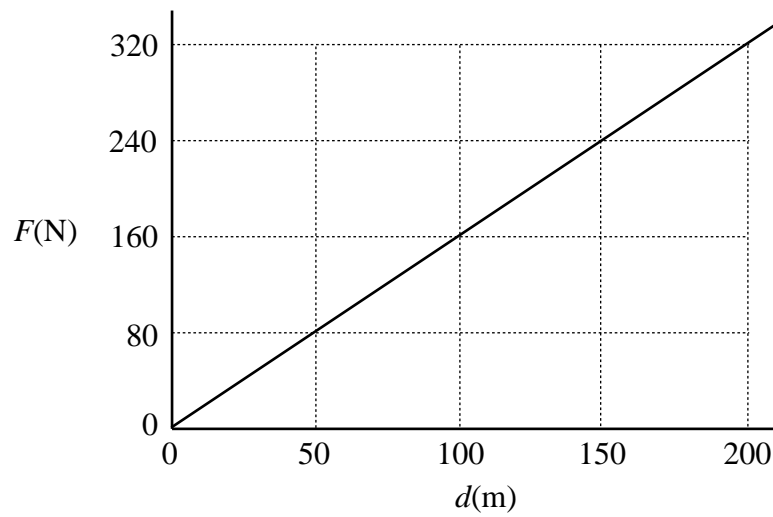

ANSWER:  speed: _____	Score for Question 2:  2. $\frac{\quad}{(7)}$
-----------------------------	--

3. A uniform 4.8 m long ladder of mass 16 kg leans against a **frictionless** vertical wall as shown in the diagram below.

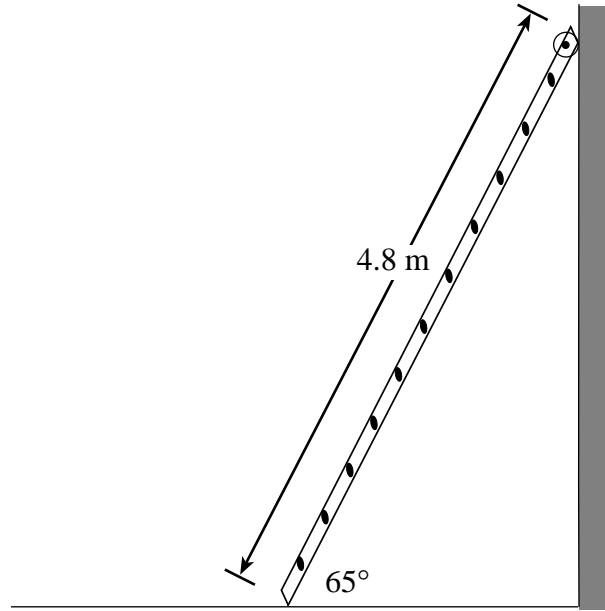

- a) Draw and label a free body diagram showing the forces acting on the ladder. **(2 marks)**



- b) What minimum force of friction is needed at the base of the ladder to keep it from sliding?  
(5 marks)

ANSWER:	Score for Question 3:
b) force of friction: _____	3. _____ (7)

**OVER**

4. A  $4.2 \times 10^3$  kg spacecraft orbits a  $5.6 \times 10^{26}$  kg planet. If it takes the spacecraft  $8.9 \times 10^4$  s to complete one orbit, how far is it from the planet's centre? **(7 marks)**

ANSWER:	Score for Question 4:
distance: _____	4. $\frac{\quad}{(7)}$

5. A  $9.0\text{ V}$  battery with an internal resistance of  $0.80\ \Omega$  is connected to two resistors as shown below. Determine the terminal voltage  $V_{ab}$  of the battery. **(7 marks)**

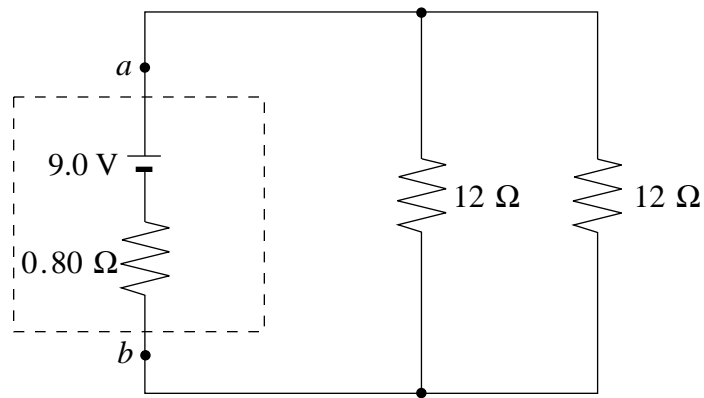

ANSWER:  terminal voltage: _____	Score for Question 5:  5. $\frac{\quad}{(7)}$
--	--

6. A 0.025 m wire segment is positioned in a 0.75 T magnetic field as shown in the diagram below. When a current is passed through this wire segment it experiences a 0.20 N force upwards.

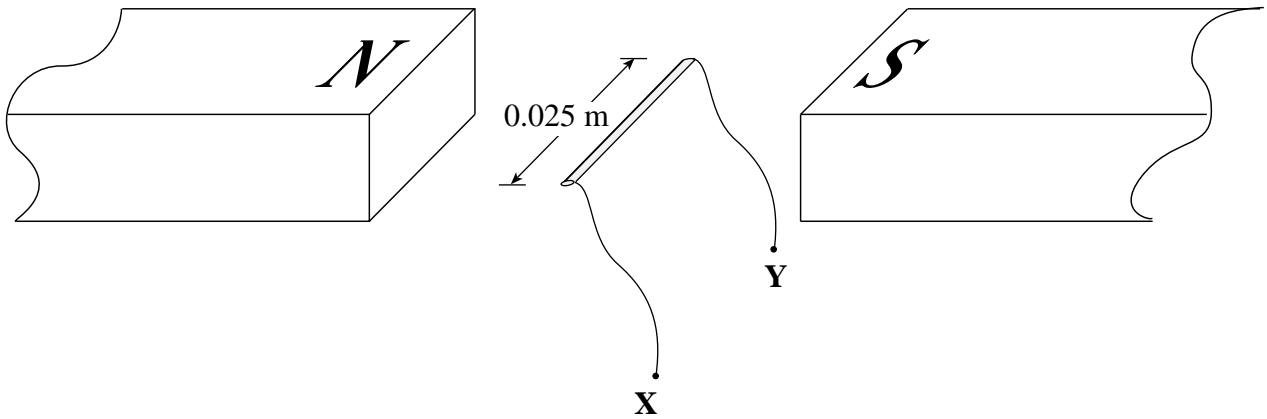

- a) What is the direction of the current? (Circle one.)

(2 marks)

From **X** to **Y**

From **Y** to **X**

b) What is the magnitude of the current?

(5 marks)

ANSWER:  magnitude of current: _____	Score for Question 6:  6. _____ (7)
--	---

7. A wire is stretched between two posts. A mass is suspended near the centre as shown below.

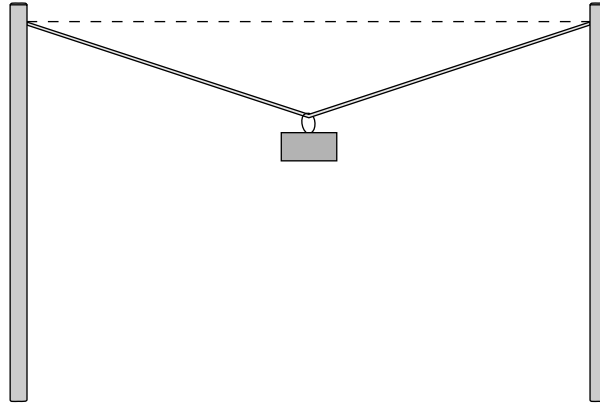

If the tension in the wire were increased, is it possible to make the wire perfectly horizontal?  
Explain your answer in terms of forces. **(4 marks)**

---

---

---

---

---

---

---

Score for Question 7:
7. <u>      </u> (4)

**This is the end of the written-response section.**



## PART C: ELECTED TOPICS

Value: 12 marks

Suggested Time: 12 minutes

### INSTRUCTIONS

1. Choose **only one** section from the three sections in this part of the examination.

SECTION I: Quantum Mechanics (p. 28 to 31)

**or**

SECTION II: Fluid Theory (p. 32 to 35)

**or**

SECTION III: AC Circuitry and Electronics (p. 36 to 39)

2. If you answer questions in more than one section, only the answers in the first section chosen will be marked.
3. Answer **all** of the questions in the section that you choose. **Write your answers in the space provided in this booklet.**
4. Rough-work space has been incorporated into the space allowed for answering each question. You may not need all of the space provided to answer each question.
5.
  - a) Final answers must include appropriate **units**.
  - b) Marks will not be deducted for answers expressed to **two** or **three** significant figures.
  - c) In this examination the zero in a number such as 30 shall be considered to be a significant zero.
6. Since partial marks will be awarded for a partial solution, it is important that you provide a clear indication of the steps leading to your answer.

**Full marks will NOT be given for the final answer only.**

I have selected SECTION \_\_\_\_\_.

**OVER**

## SECTION I: Quantum Mechanics

1. What is the momentum of a photon with a frequency of  $5.09 \times 10^{14}$  Hz ?

**(3 marks)**

ANSWER:  momentum: _____	Score for Question 1:  8. _____ (3)
--------------------------------	---

**SECTION I: Continued**

2. A metal surface has a work function of  $3.68 \text{ eV}$ . Incident light causes photoelectrons to be emitted with a maximum kinetic energy of  $1.36 \times 10^{-19} \text{ J}$ . What is the wavelength of the incident light?  
**(4 marks)**

ANSWER:  wavelength: _____	Score for Question 2:  9. _____ (4)
----------------------------------	---

**OVER**

**SECTION I: Continued**

3. The electron in a hydrogen atom is in the excited state  $n = 3$ .
- a) As the atom emits energy, how many different frequencies of light can be produced?

**(2 marks)**

b) Calculate the lowest frequency of light emitted by this atom.

**(3 marks)**

ANSWER:

number of frequencies: \_\_\_\_\_

lowest frequency: \_\_\_\_\_

Score for  
Question 3:

10. \_\_\_\_\_  
(5)

**END OF SECTION I: Quantum Mechanics**

**OVER**

## SECTION II: Fluid Theory

1. A horizontal pipe of cross-sectional area  $3.0 \times 10^{-2} \text{ m}^2$  tapers to a cross-sectional area of  $1.5 \times 10^{-2} \text{ m}^2$ . If the speed of water in the wide section of pipe is 4.0 m/s, what is the speed of the water in the narrow section of pipe? **(3 marks)**

ANSWER:	Score for Question 1:
speed: _____	11. _____ (3)

**SECTION II: Continued**

2. A 48 kg girl and a car of mass  $m$  are placed on a hydraulic lift as shown in the diagram below. The area of the piston the girl stands on is  $7.0 \times 10^{-3} \text{ m}^2$ , while the area of the piston under the car is  $0.12 \text{ m}^2$ .

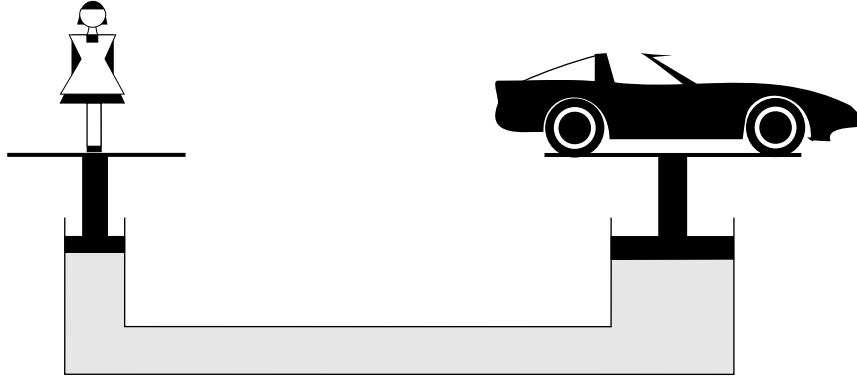

What maximum car mass  $m$  can be supported in this situation?

**(4 marks)**

ANSWER:	Score for Question 2:
mass: _____	12. _____ (4)

**OVER**

**SECTION II: Continued**

3. An  $18 \text{ m}^3$  container holds  $1\,200$  moles of oxygen at a pressure of  $1.5 \times 10^5 \text{ Pa}$ . If the mass of an oxygen molecule is  $5.3 \times 10^{-26} \text{ kg}$ , what is the rms speed of the molecules? **(5 marks)**



ANSWER:

rms speed: \_\_\_\_\_

Score for  
Question 3:

13. \_\_\_\_\_  
(5)

**END OF SECTION II: Fluid Theory**

**OVER**

### SECTION III: AC Circuitry and Electronics

1. A transistor has a current gain of 150. When the base current increases from  $5.0 \mu\text{A}$  to  $7.5 \mu\text{A}$ , what is the change in the collector current? **(3 marks)**

ANSWER:	Score for Question 1:
change in collector current: _____	14. _____ (3)

**SECTION III: Continued**

2. The circuit show in the diagram below resonates at 1 410 kHz.

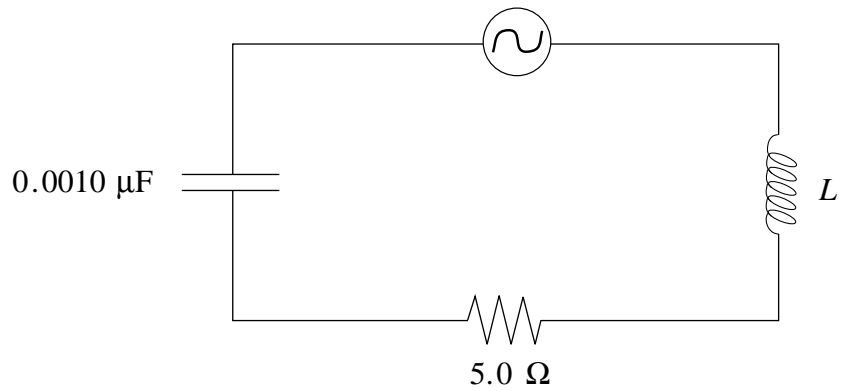

What is the inductance?

**(4 marks)**

ANSWER:	Score for Question 2:
inductance: _____	15. _____ (4)

**OVER**

**SECTION III: Continued**

3. Determine the voltage across capacitor  $C_2$ .

**(5 marks)**

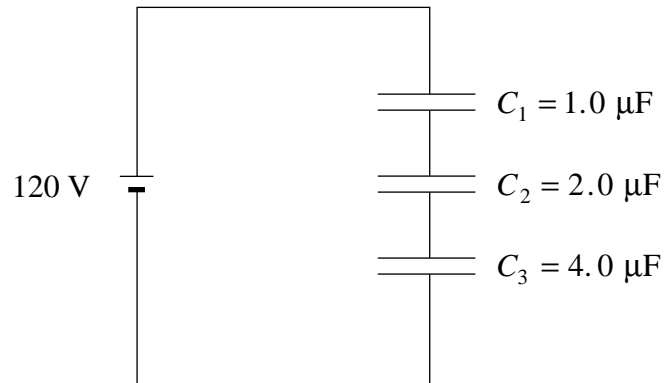

ANSWER:

voltage: \_\_\_\_\_

Score for  
Question 3:

16. \_\_\_\_\_  
(5)

**END OF SECTION III: AC Circuitry and Electronics**

**END OF EXAMINATION**

**THIS PAGE INTENTIONALLY BLANK**

## DATA TABLE

Gravitational constant .....	$G = 6.67 \times 10^{-11} \text{ N} \cdot \text{m}^2/\text{kg}^2$
Acceleration due to gravity at the surface of Earth (for the purposes of this examination) .....	$g = 9.80 \text{ m/s}^2$
<b>Earth</b>	
radius .....	$= 6.38 \times 10^6 \text{ m}$
radius of orbit about Sun .....	$= 1.50 \times 10^{11} \text{ m}$
period of rotation .....	$= 8.61 \times 10^4 \text{ s}$
period of revolution about Sun .....	$= 3.16 \times 10^7 \text{ s}$
mass .....	$= 5.98 \times 10^{24} \text{ kg}$
<b>Moon</b>	
radius .....	$= 1.74 \times 10^6 \text{ m}$
radius of orbit about Earth .....	$= 3.84 \times 10^8 \text{ m}$
period of rotation .....	$= 2.36 \times 10^6 \text{ s}$
period of revolution about Earth .....	$= 2.36 \times 10^6 \text{ s}$
mass .....	$= 7.35 \times 10^{22} \text{ kg}$
<b>Sun</b>	
mass .....	$= 1.98 \times 10^{30} \text{ kg}$
Constant in Coulomb's Law .....	$k = 9.00 \times 10^9 \text{ N} \cdot \text{m}^2/\text{C}^2$
Elementary charge .....	$e = 1.60 \times 10^{-19} \text{ C}$
Mass of electron .....	$m_e = 9.11 \times 10^{-31} \text{ kg}$
Mass of proton .....	$m_p = 1.67 \times 10^{-27} \text{ kg}$
Mass of neutron .....	$m_n = 1.68 \times 10^{-27} \text{ kg}$
Permeability of free space .....	$\mu_o = 4\pi \times 10^{-7} \text{ T} \cdot \text{m/A}$
Planck's constant .....	$h = 6.63 \times 10^{-34} \text{ J} \cdot \text{s}$ $h = 4.14 \times 10^{-15} \text{ eV} \cdot \text{s}$
Speed of light .....	$c = 3.00 \times 10^8 \text{ m/s}$
Rydberg's constant .....	$R = 1.097 \times 10^7 \text{ m}^{-1}$
Unified atomic mass unit .....	$u = 1.66 \times 10^{-27} \text{ kg}$
Boltzmann's constant .....	$k = 1.38 \times 10^{-23} \text{ J/K}$
Gas constant .....	$R = 8.31 \text{ J/mol} \cdot \text{K}$
Density of water .....	$= 1.00 \times 10^3 \text{ kg/m}^3$
Density of air .....	$= 1.29 \text{ kg/m}^3$
Standard atmospheric pressure .....	$= 1.01 \times 10^5 \text{ Pa}$
Volume of one mole of gas at STP .....	$= 22.4 \text{ L} (2.24 \times 10^{-2} \text{ m}^3)$
Avogadro's number .....	$N = 6.02 \times 10^{23} \text{ particles/mol}$
Absolute zero .....	$= -273^\circ \text{C}$

**You may detach this page for convenient reference.  
Exercise care when tearing along perforations.**

# TRIGONOMETRIC AND OTHER EQUATIONS

## For Right-angled Triangles:

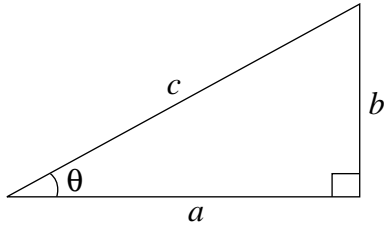

$$a^2 + b^2 = c^2$$

$$\sin \theta = \frac{b}{c} \quad \cos \theta = \frac{a}{c} \quad \tan \theta = \frac{b}{a}$$

$$\text{area} = \frac{1}{2} ab$$

## For All Triangles:

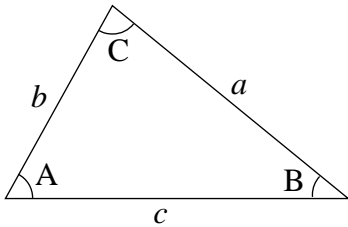

$$\text{area} = \frac{1}{2} \text{base} \times \text{height}$$

$$\sin 2A = 2 \sin A \cos A$$

$$\text{Sine Law: } \frac{\sin A}{a} = \frac{\sin B}{b} = \frac{\sin C}{c}$$

$$\text{Cosine Law: } c^2 = a^2 + b^2 - 2ab \cos C$$

## Circle:

$$\text{Circumference} = 2\pi r$$

$$\text{Area} = \pi r^2$$

## Sphere:

$$\text{Surface area} = 4\pi r^2$$

$$\text{Volume} = \frac{4}{3}\pi r^3$$

## Quadratic Equation:

$$\text{If } ax^2 + bx + c = 0, \text{ then } x = \frac{-b \pm \sqrt{b^2 - 4ac}}{2a}$$



## EQUATIONS

**Note: Vector quantities have not been indicated.**

### 1. Kinematics: (for constant acceleration)

$$v = v_0 + at \qquad v_{av} = \frac{v + v_0}{2} \qquad v^2 = v_0^2 + 2ad$$

$$d = v_0t + \frac{1}{2}at^2$$

### 2. Dynamics:

$$F_f = \mu F_N \qquad F_{net} = ma$$

### 3. Mechanical Energy and Momentum:

$$W = Fd \qquad E_p = mgh \qquad E_k = \frac{1}{2}mv^2$$

$$P = \frac{W}{t} \qquad p = mv \qquad \Delta p = F_{net}\Delta t$$

### 4. Equilibrium:

$$\tau = Fd$$

### 5. Circular Motion and Gravitation:

$$a_c = \frac{v^2}{r} = \frac{4\pi^2r}{T^2} \qquad F = G\frac{m_1m_2}{r^2}$$

$$E_p = -G\frac{m_1m_2}{r} \qquad r^3 \propto T^2$$

### 6. Electrostatics:

$$F = k\frac{Q_1Q_2}{r^2} \qquad E = \frac{V}{d} \qquad V = \frac{kQ}{r}$$

$$E_p = k\frac{Q_1Q_2}{r} \qquad F = QE \qquad V = \frac{\Delta E_p}{Q}$$

### 7. Circuitry:

$$Q = It \qquad V = IR \qquad P = VI$$

**You may detach this page for convenient reference.  
Exercise care when tearing along perforations.**

## EQUATIONS (continued)

### 8. Electromagnetism:

$$\begin{array}{lll}
 F = IlB & B = \frac{\mu_0 I}{2\pi d} & \tau = NIAB \\
 F = QvB & B = \mu_0 nI \left( \text{where } n = \frac{N}{l} \right) & \Phi = BA \\
 \mathcal{E} = -N \frac{\Delta\Phi}{\Delta t} & \mathcal{E} = Blv & \frac{V_s}{V_p} = \frac{N_s}{N_p}
 \end{array}$$

### 9. Quantum Mechanics: (Section I)

$$\begin{array}{lll}
 E = hf & c = f\lambda & E_n = (-13.6eV) \frac{Z^2}{n^2} \\
 E_{k_{\max}} = hf - W_0 & \lambda = \frac{h}{p} &
 \end{array}$$

### 10. Fluid Theory: (Section II)

$$\begin{array}{lll}
 \rho = \frac{m}{V} & PV = NkT & PV = \frac{1}{3} Nmv^2 \\
 F = \rho Vg & P = \frac{F}{A} & P = P_G + P_a \\
 PV = nRT & P + \frac{1}{2}\rho v^2 + \rho gh = \text{constant} & E_k = \frac{3}{2}kT \\
 & Av = \text{constant} &
 \end{array}$$

### 11. AC Circuits and Electronics: (Section III)

$$\begin{array}{lll}
 Q = CV & E_p = \frac{1}{2} CV^2 & \tau = RC \\
 X_C = \frac{1}{2\pi fC} & Z = \sqrt{R^2 + (X_L - X_C)^2} & X_L = 2\pi fL \\
 f_0 = \frac{1}{2\pi\sqrt{LC}} & \beta \text{ (current gain)} = \frac{\Delta I_C}{\Delta I_B} & A_f = \frac{A}{1 - \beta A} \\
 & & \text{(where } \beta = \text{ feedback ratio)}
 \end{array}$$

**ROUGH WORK FOR MULTIPLE-CHOICE**

**You may detach this page for convenient reference.  
Exercise care when tearing along perforations.**

## ROUGH WORK FOR MULTIPLE-CHOICE