

MINISTRY USE ONLY



MINISTRY USE ONLY



Place Personal Education Number (PEN) here.

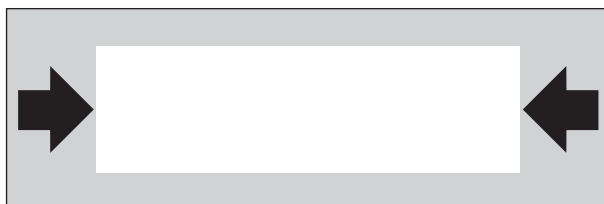

Place Personal Education Number (PEN) here.

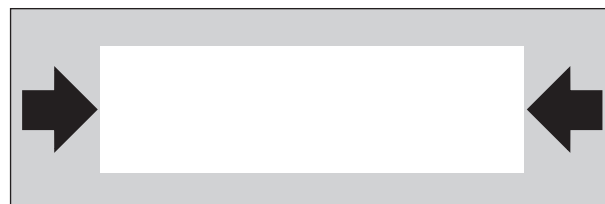

MINISTRY USE ONLY



**BRITISH  
COLUMBIA**  
© 2004 Ministry of Education

**Physics 12**  
**JANUARY 2004**  
**Course Code = PH**

### Student Instructions

1. Place the stickers with your Personal Education Number (PEN) in the allotted spaces above. **Under no circumstance is your name or identification, other than your Personal Education Number, to appear on this booklet.**
2. Ensure that in addition to this examination booklet, you have an **Examination Response Form**. Follow the directions on the front of the Response Form.
3. **Disqualification** from the examination will result if you bring books, paper, notes or unauthorized electronic devices into the examination room.
4. When instructed to open this booklet, **check the numbering of the pages** to ensure that they are numbered in sequence from page one to the last page, which is identified by  

**END OF EXAMINATION**

.
5. At the end of the examination, place your Response Form inside the front cover of this booklet and return the booklet and your Response Form to the supervisor.

Question 1:

1.  .

(7)

Question 8:

8.  .

(5)

Question 2:

2.  .

(7)

Question 9:

9.  .

(4)

Question 3:

3.  .

(7)

Question 4:

4.  .

(7)

Question 5:

5.  .

(7)

Question 6:

6.  .

(7)

Question 7:

7.  .

(9)

**PHYSICS 12**

**JANUARY 2004**

COURSE CODE = PH

## GENERAL INSTRUCTIONS

1. Aside from an approved calculator, electronic devices, including dictionaries and pagers, are **not** permitted in the examination room.
2. Ensure that your calculator is in degree mode.
3. All multiple-choice answers must be entered on the Response Form using an **HB pencil**. Multiple-choice answers entered in this examination booklet will **not** be marked.
4. For each of the written-response questions, write your answer in the space provided in this booklet. Rough-work space has been incorporated into the space allowed for answering each written-response question. You may not need all of the space provided to answer each question.
5. Ensure that you use language and content appropriate to the purpose and audience of this examination. Failure to comply may result in your paper being awarded a zero.
6. This examination is designed to be completed in **two hours**. *Students may, however, take up to 30 minutes of additional time to finish.*

## PHYSICS 12 PROVINCIAL EXAMINATION

- |   | Value                   | Suggested Time     |
|---|-------------------------|--------------------|
| 1. This examination consists of <b>two</b> parts:         |                         |                    |
| PART A: 30 multiple-choice questions worth two marks each | 60 marks                | 60 minutes         |
| PART B: 9 written-response questions                      | 60 marks                | 60 minutes         |
|   | <b>Total: 120 marks</b> | <b>120 minutes</b> |
2. The last **three** pages inside the back cover contain the **Table of Constants, Mathematical Equations, Formulae, and Rough Work for Multiple-Choice**. These pages may be detached for convenient reference prior to writing this examination.
3. **A calculator is essential for the Physics 12 Provincial Examination.** The calculator must be a hand-held device designed primarily for mathematical computations involving logarithmic and trigonometric functions and may be capable of performing graphing functions. Computers, calculators with a QWERTY keyboard or symbolic manipulation abilities, and electronic writing pads will not be allowed. Students must not bring any external devices (peripherals) to support calculators such as manuals, printed or electronic cards, printers, memory expansion chips or cards, CD-ROMs, libraries or external keyboards. Students may have more than one calculator available during the examination, of which one may be a scientific calculator. Calculators may not be shared and must not have the ability to either transmit or receive electronic signals. In addition to an approved calculator, students will be allowed to use rulers, compasses, and protractors during the examination.
4. a) Final answers must include appropriate **units**.  
b) Marks will not be deducted for answers expressed to **two** or **three** significant figures.  
c) In this examination the zero in a number such as 30 shall be considered to be a significant zero.
5. You are expected to communicate your knowledge and understanding of physics principles in a clear and logical manner. Partial marks will be awarded for steps and assumptions leading to a solution. Full marks will **not** be awarded for providing **only** a final answer.

If you are unable to determine the value of a quantity required in order to proceed, you may assume a reasonable value and continue toward the solution. Such a solution, however, may not be eligible for full marks.

**THIS PAGE INTENTIONALLY BLANK**

**PART A: MULTIPLE CHOICE**

**Value: 60 marks (2 marks per question)**

**Suggested Time: 60 minutes**

**INSTRUCTIONS:** For each question, select the **best** answer and record your choice on the Response Form provided. Using an HB pencil, completely fill in the circle on the Response Form that has the letter corresponding to your answer.

1. Which of the following contains vector quantities only?

- A. mass, speed
- B. energy, velocity
- C. displacement, energy
- D. displacement, velocity

2. Which of the following vector diagrams shows  $\vec{A}$  as the sum of  $\vec{B}$  and  $\vec{C}$  (i.e.  $\vec{A} = \vec{B} + \vec{C}$ )?

A.

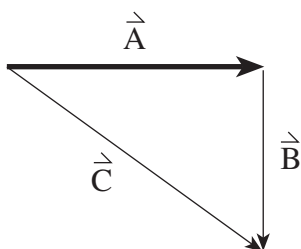

B.

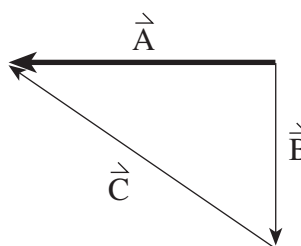

C.

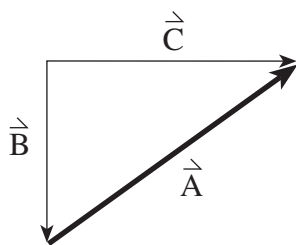

D.

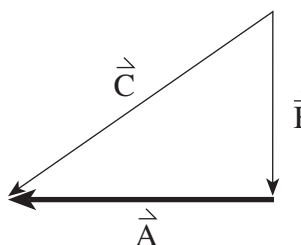

3. A projectile is launched with a velocity of 35 m/s at 55° above the horizontal. What is the maximum height reached by the projectile? Ignore friction.

- A. 5.3 m
- B. 42 m
- C. 54 m
- D. 63 m

**OVER**

4. If the net force on a falling object is zero, then the object has
- A. constant speed.
  - B. constant altitude.
  - C. no kinetic energy.
  - D. no potential energy.
5. Two masses, one of 1.0 kg, the other of 3.0 kg, are suspended from the ends of a light string passing over a frictionless pulley.

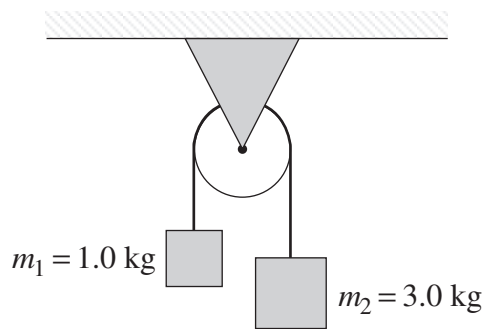

What is the magnitude of the acceleration of these masses?

- A.  $2.5 \text{ m/s}^2$
  - B.  $4.9 \text{ m/s}^2$
  - C.  $7.4 \text{ m/s}^2$
  - D.  $9.8 \text{ m/s}^2$
6. A 2.0 kg mass is suspended by a spring scale from the ceiling of an elevator. If the spring scale reads 25 N, then the acceleration of the elevator is
- A.  $2.7 \text{ m/s}^2$  upwards.
  - B.  $2.7 \text{ m/s}^2$  downwards.
  - C.  $13 \text{ m/s}^2$  upwards.
  - D.  $13 \text{ m/s}^2$  downwards.



7. A 10 kg block initially at rest is pulled 13 m across a floor by a 50 N force.

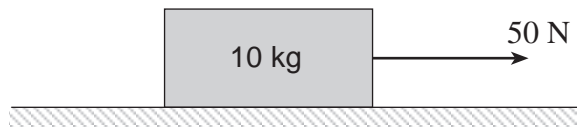

If friction does 380 J of work over this distance, what is the block's final velocity?

- A. 7.3 m/s  
 B. 8.7 m/s  
 C. 11 m/s  
 D. 14 m/s
8. A small rubber ball moving at high speed strikes a stationary cart. As a result of the collision, the rubber ball rebounds and the cart rolls forward. Which object experienced the greater magnitude of impulse?
- A. Cart  
 B. Rubber ball  
 C. Both experienced the same magnitude of impulse.  
 D. It depends on whether the collision was elastic or inelastic.
9. An object experiences a varying force as shown in the following  $F-t$  graphs. Which graph shows the largest change in momentum?

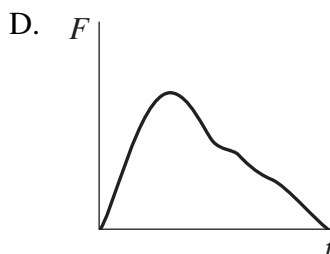
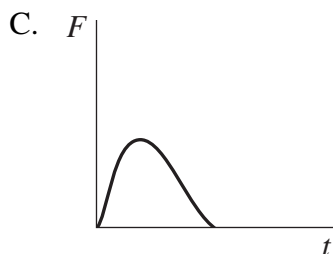
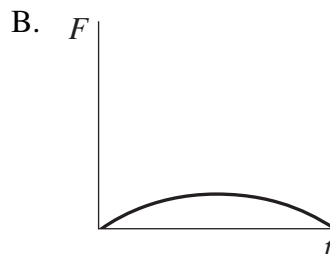
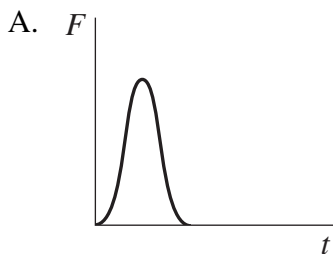

10. A 200 kg object moving at 15 m/s due east collides with a 100 kg block moving at 15 m/s due north. The objects stick together following the collision. What is the speed of the 200 kg object immediately after the collision?
- A. 5.0 m/s
  - B. 11 m/s
  - C. 15 m/s
  - D. 21 m/s
11. Outside the International Space Station, a 60 kg astronaut holding a 4.0 kg object (both initially at rest) throws the object at 10 m/s relative to the space station. A 50 kg astronaut, initially at rest, catches the object. What is the speed of separation of the two astronauts?
- A. 0.67 m/s
  - B. 0.80 m/s
  - C. 1.4 m/s
  - D. 1.5 m/s
12. Which of these is an acceptable definition of rotational equilibrium?
- A.  $\Sigma\tau = 0$
  - B.  $\Sigma v = 0$
  - C.  $\Sigma F = \Sigma\tau$
  - D.  $\Sigma F_x = \Sigma F_y$

13. A 25 kg mass is suspended from the end of a 5.0 m long uniform boom.

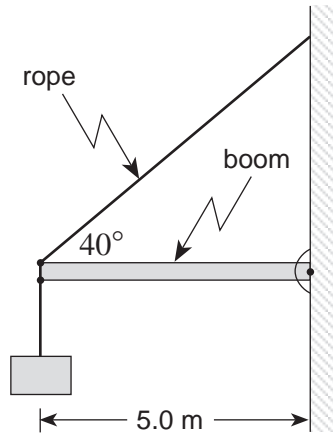

If the mass of the boom is 12 kg, what is the tension in the supporting rope?

- A. 300 N
  - B. 380 N
  - C. 470 N
  - D. 560 N
14. A uniform 16 m long plank weighing 350 N rests on supports 8.0 m apart. An 850 N man walks along the plank to the right.

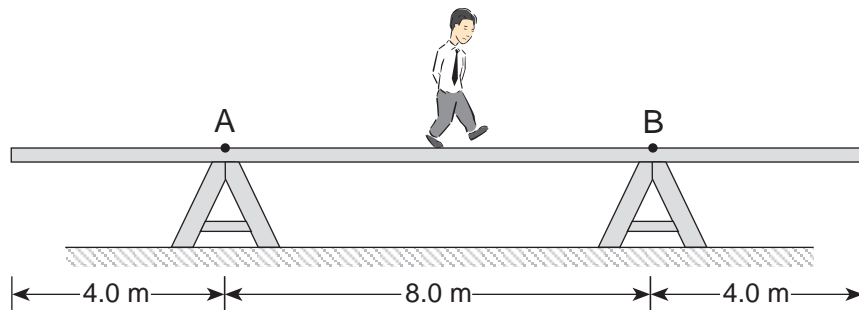

How far past point B can the man walk before the plank tips?

- A. 0.82 m
- B. 1.6 m
- C. 2.5 m
- D. 3.3 m

15. When an object is in uniform circular motion,

- A. its speed is constant.
- B. its velocity is constant.
- C. its acceleration is constant.
- D. the net force on the object is constant.

16. A toy airplane, suspended by a light thread, is moving in a circular path at a constant speed as shown.

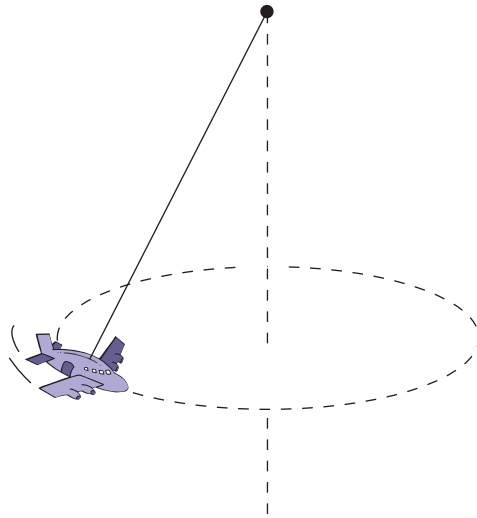

Which of the following is the correct free body diagram for the toy airplane?

A.



B.



C.

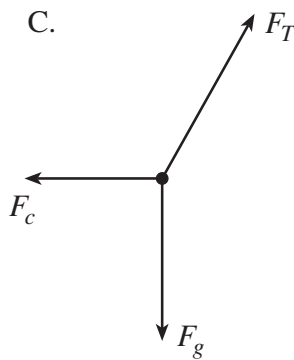

D.

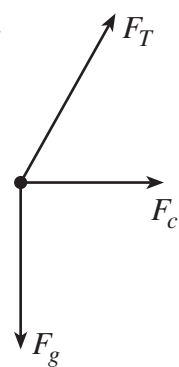

17. A 1400 kg car is travelling at 25 m/s on a circular hill of radius 210 m. What is the normal force on this car at the top of the hill?

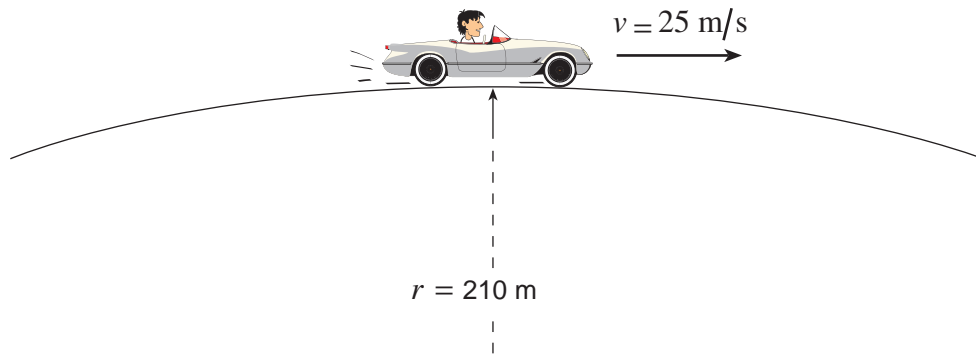

- A.  $4.2 \times 10^2 \text{ N}$   
B.  $9.6 \times 10^3 \text{ N}$   
C.  $1.4 \times 10^4 \text{ N}$   
D.  $2.3 \times 10^4 \text{ N}$
18. In an amusement park, a 2.8 m radius “drum” rotates such that a person does not fall when the “floor” drops away.

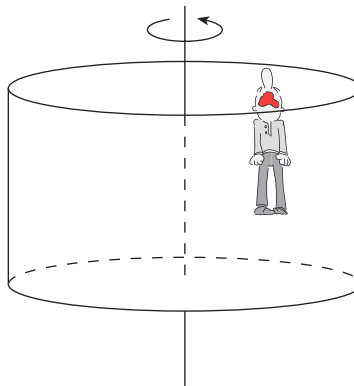

If the coefficient of friction between the person and the wall is 0.35, what is the maximum period of the rotation so that a person will not fall?

- A. 2.0 s  
B. 3.4 s  
C. 5.7 s  
D. 18 s

19. Which of the following is a correct statement about gravitational force?

- A. It is applicable only to our solar system.
- B. It is both an attractive and repulsive force.
- C. It is directly proportional to the product of the masses involved.
- D. It is directly proportional to both the mass and radius of the earth.

20. What does an electric field line indicate?

- A. The direction of the electrostatic force on a positive charge.
- B. The direction of the electrostatic force on a negative charge.
- C. The magnitude of the electrostatic force on a positive charge.
- D. The magnitude of the electrostatic force on a negative charge.

21. What is the magnitude of the electric field at point P in the diagram below? ( $1 \mu\text{C} = 1 \times 10^{-6} \text{ C}$ )

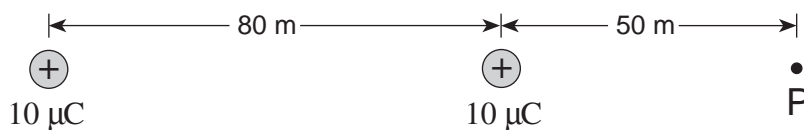

- A. 22 N/C
- B. 31 N/C
- C. 41 N/C
- D. 50 N/C

22. A positive charge Q is located several metres from a fixed positive charge as shown in the diagram below.



You are told to move charge Q a distance of 1.0 m so as to cause the greatest increase in its electrical potential energy. In which direction do you move it?

- A. 1
- B. 2
- C. 3
- D. 4

23. Which of the following statements is true for the electric circuit shown below, regardless of the resistors used?

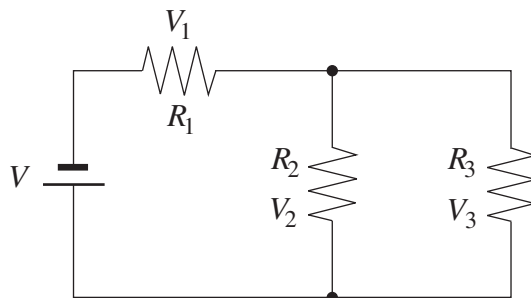

- A.  $V_1 = V_2$
- B.  $V = V_2 + V_3$
- C.  $V = V_1 + V_3$
- D.  $V = V_1 + V_2 + V_3$

24. What value of  $R$  in the circuit shown below will cause the parallel combination ( $10\ \Omega$  and  $R$ ) to dissipate the same power as the  $4.0\ \Omega$  resistor?

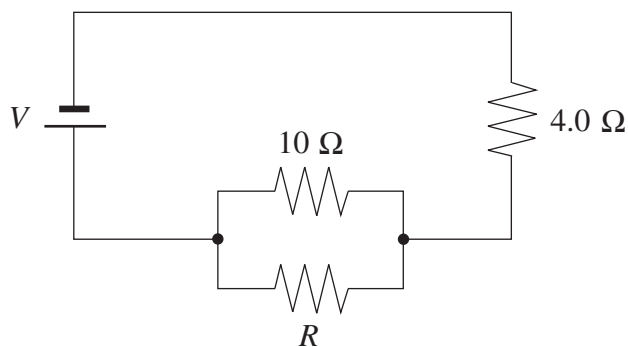

- A.  $0.26\ \Omega$
- B.  $2.9\ \Omega$
- C.  $6.0\ \Omega$
- D.  $6.7\ \Omega$

25. Which of the following best represents the magnetic field between two magnets?

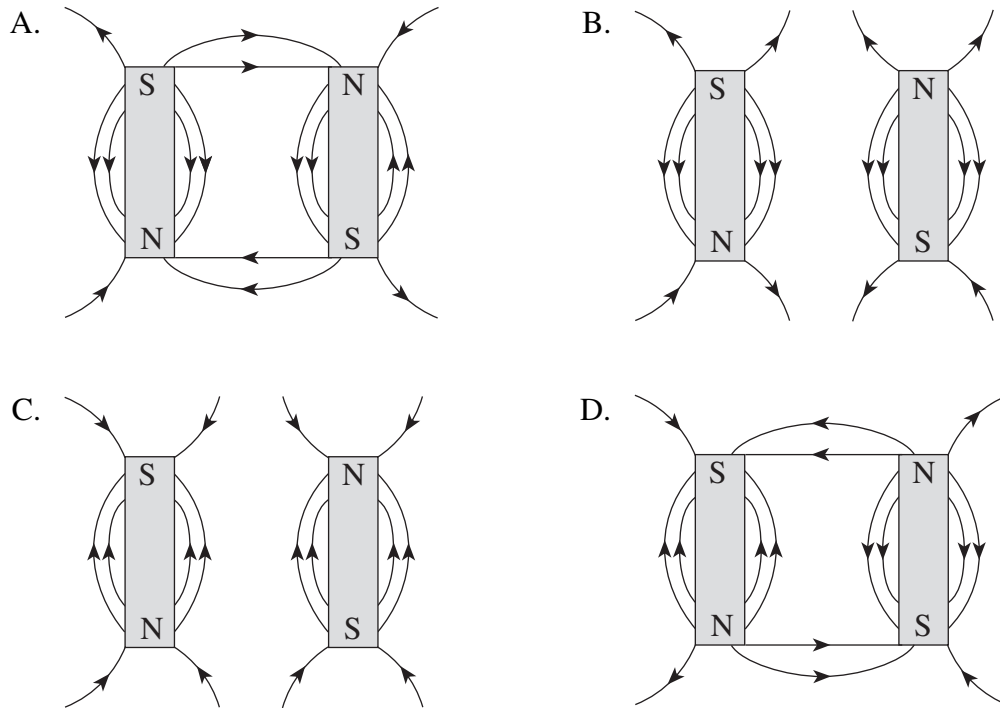

26. Which of the four arrows indicates the direction of the magnetic field when current flows in the solenoid shown below?

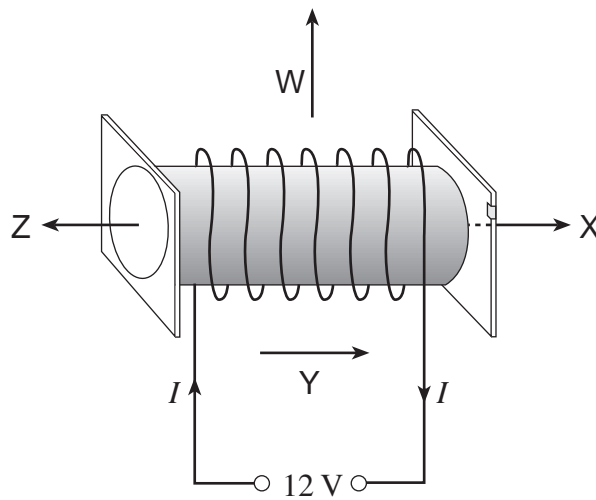

- A. W
- B. X
- C. Y
- D. Z



27. A 0.40 m length of copper rod is held perpendicularly to a 0.082 T magnetic field as shown.

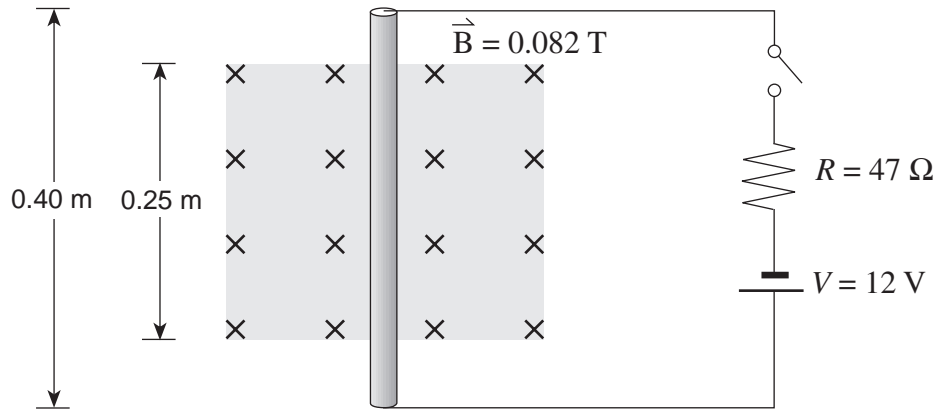

The copper rod is connected to a 12 V power supply and a 47 ohm resistor. What are the magnitude and direction of the magnetic force on the copper rod when the switch is closed?

	MAGNITUDE OF FORCE (N)	DIRECTION OF FORCE
A.	$5.2 \times 10^{-3}$	left
B.	$5.2 \times 10^{-3}$	right
C.	$8.4 \times 10^{-3}$	left
D.	$8.4 \times 10^{-3}$	right

**OVER**

28. A 0.35 m length of a conducting rod is moving perpendicular to a 0.026 T magnetic field as shown.

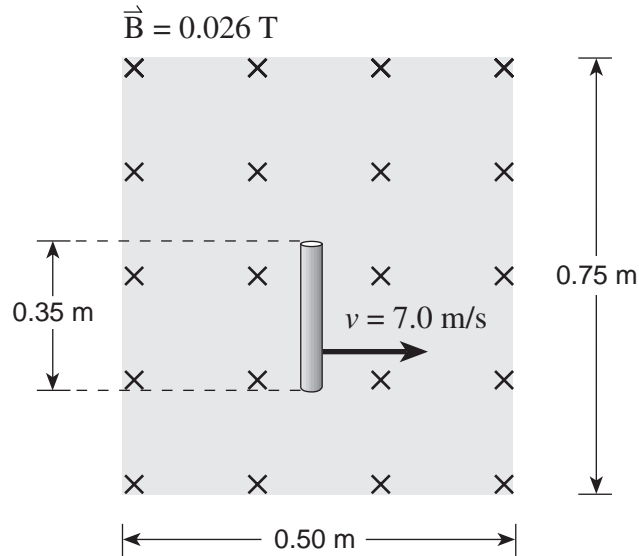

What is the potential difference as measured across the ends of the conducting rod?

- A. 0.0 V
  - B. 0.064 V
  - C. 0.091 V
  - D. 0.13 V
29. Which of the four situations below shows the greatest amount of magnetic flux for a rectangular coil?

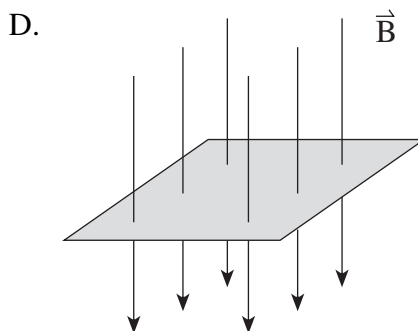
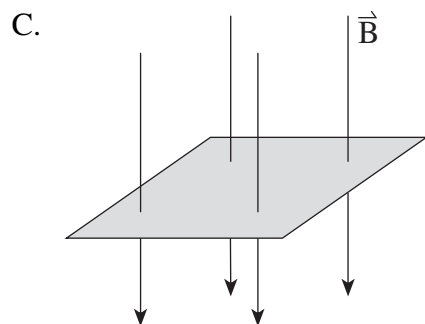
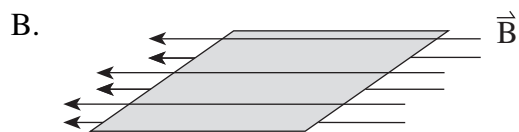
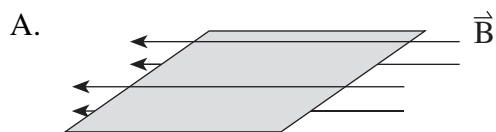

30. An ideal 2.25 W transformer changes 120 V to 4.5 V for use in portable electronic devices. What is the current in the secondary windings and the ratio of primary coils to secondary coils in this transformer?

	SECONDARY CURRENT	RATIO OF <b>PRIMARY</b> TO <b>SECONDARY</b> COILS
A.	0.50 A	27 to 1
B.	0.50 A	1 to 27
C.	2.0 A	27 to 1
D.	2.0 A	1 to 27

**This is the end of the multiple-choice section.  
Answer the remaining questions directly in this examination booklet.**

**OVER**

**THIS PAGE INTENTIONALLY BLANK**

## PART B: WRITTEN RESPONSE

Value: 60 marks

Suggested Time: 60 minutes

### INSTRUCTIONS:

1. Rough-work space has been incorporated into the space allowed for answering each written-response question. You may not need all of the space provided to answer each question.
2.
  - a) Final answers must include appropriate **units**.
  - b) Marks will not be deducted for answers expressed to **two** or **three** significant figures.
  - c) In this examination the zero in a number such as 30 shall be considered to be a significant zero.
3. You are expected to communicate your knowledge and understanding of physics principles in a clear and logical manner. Partial marks will be awarded for steps and assumptions leading to a solution.
4. If you are unable to determine the value of a quantity required in order to proceed, you may assume a reasonable value and continue toward the solution. Such a solution, however, may not be eligible for full marks.
5. **Full marks will NOT be awarded for providing only a final answer.**

1. A system of masses is connected by a light cord passing over a pulley as shown in the diagram.

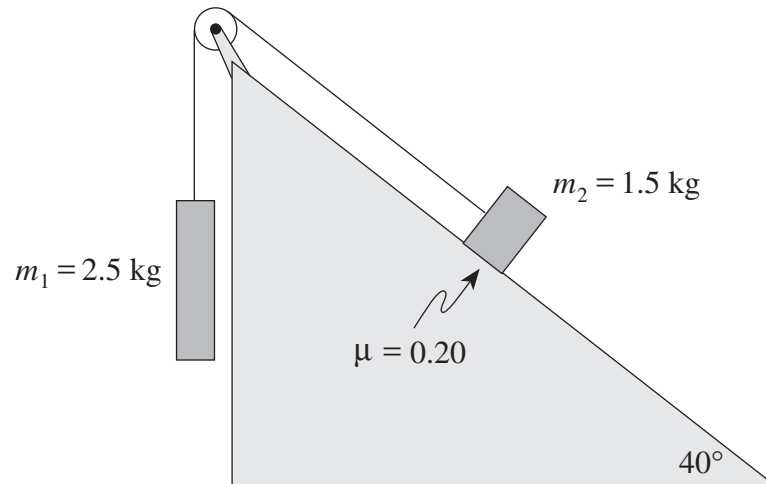

- a) Draw a labelled free body diagram for mass  $m_2$ .

**(2 marks)**

b) What is the magnitude of the acceleration of the system of masses?

**(5 marks)**

ANSWER:

b) magnitude of the acceleration:

\_\_\_\_\_

**OVER**

2. An electric motor and a rope are used to pull a 10 kg crate of car parts up an inclined plane as shown below. The crate starts out from rest on the ground and ends up with speed  $v_f$  at a height of 4.0 m above the ground.

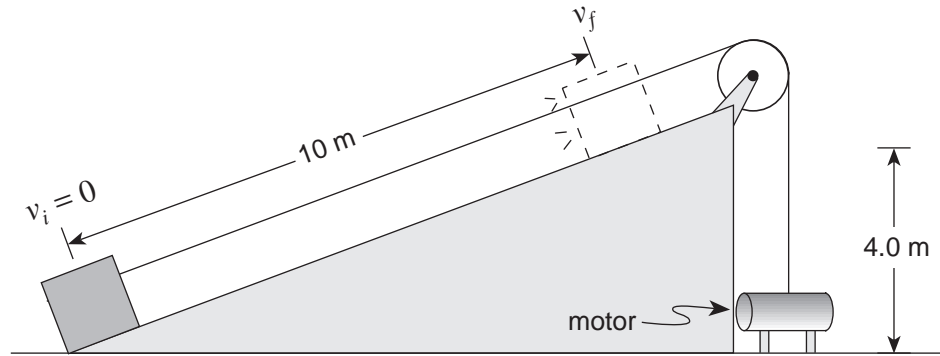

The graph below shows the force exerted on the crate by the motor as it is pulled 10 m up the inclined plane.

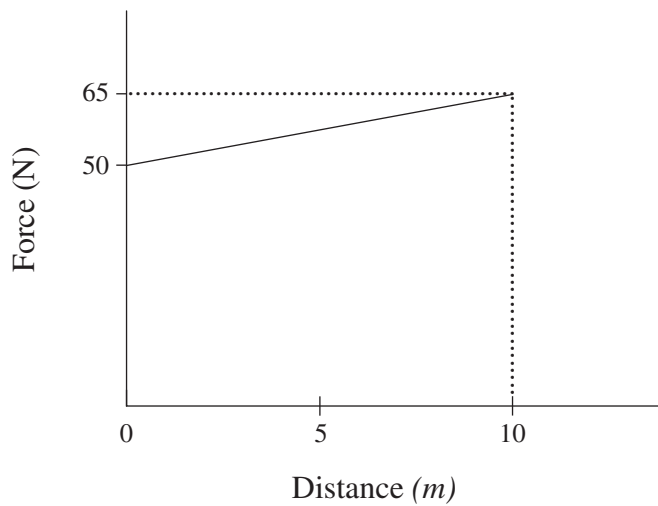



- a) How much work is done on the crate by the electric motor from  $d = 0$  m to  $d = 10$  m?  
(3 marks)

ANSWER:

a) work done on the crate:

\_\_\_\_\_

- b) 150 J of heat energy is produced through friction during the 10 m pull. What is the final speed of the crate at  $d = 10$  m?  
(4 marks)

ANSWER:

b) final speed: \_\_\_\_\_

3. A uniform 4.0 m long beam with a mass of 15 kg rests on a pivot at one end and is kept horizontal by a cable at the other end. The beam is supporting a 25 kg mass as shown. What is the tension in the cable? **(7 marks)**

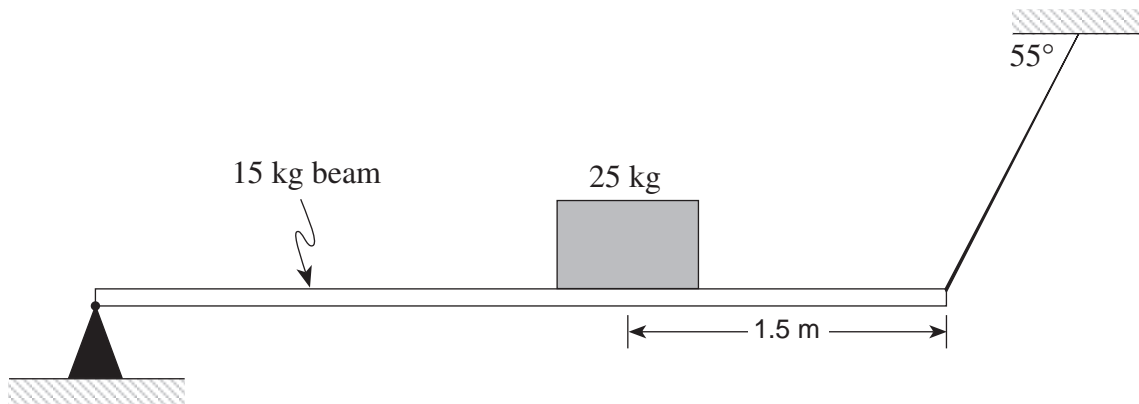

ANSWER:

tension in the cable: \_\_\_\_\_

**OVER**

4. A stationary  $1.60 \times 10^3$  kg vehicle is taken from the surface of the moon and placed into a circular orbit at a height of  $2.0 \times 10^6$  m above the surface of the moon. Its speed in this orbit is  $1.15 \times 10^3$  m/s. How much work is required for this process? **(7 marks)**

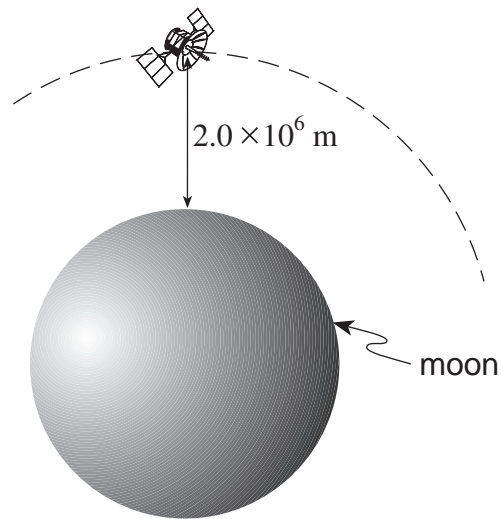

ANSWER:  
work required:

---

5. The potential difference in moving from position  $a$  to position  $b$  ( $\Delta V_{a \rightarrow b}$ ) in the diagram below is equal to  $+400 \text{ V}$ . Determine the size and polarity of the charge  $Q$ . **(7 marks)**

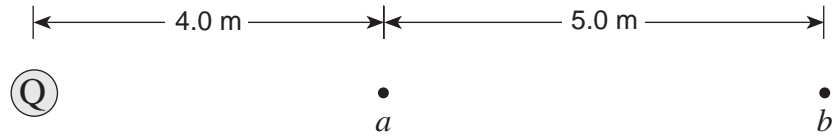

ANSWER:

size of charge Q: \_\_\_\_\_

polarity of charge Q: \_\_\_\_\_

**OVER**

6. The current through the  $8.0 \Omega$  resistor shown below is  $0.60 \text{ A}$ . Determine the terminal voltage of the battery. (7 marks)

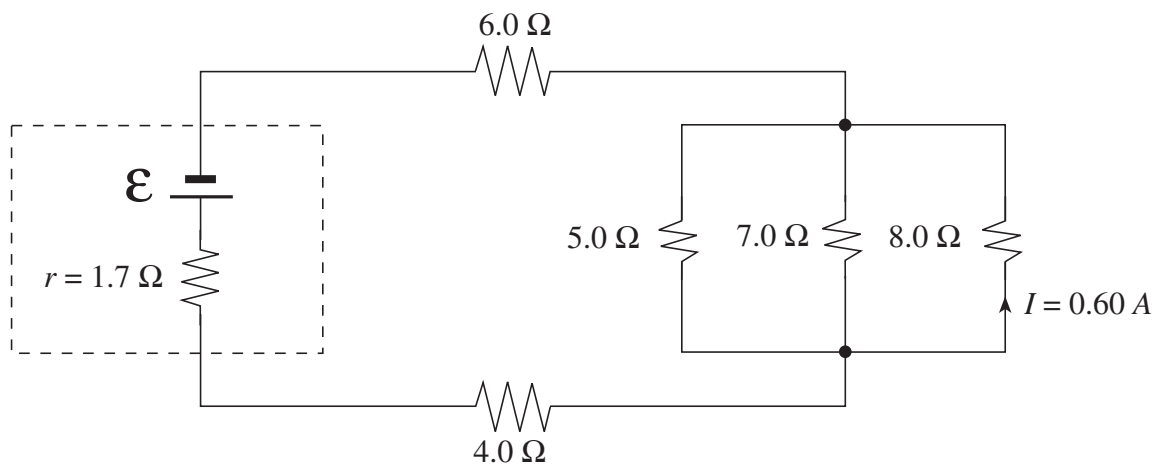



ANSWER:  
terminal voltage: \_\_\_\_\_

**OVER**

7. A solenoid placed beneath a cathode ray tube as shown below produces a magnetic field of  $0.011\text{ T}$  on the electron beam causing it to hit the screen at position 1.

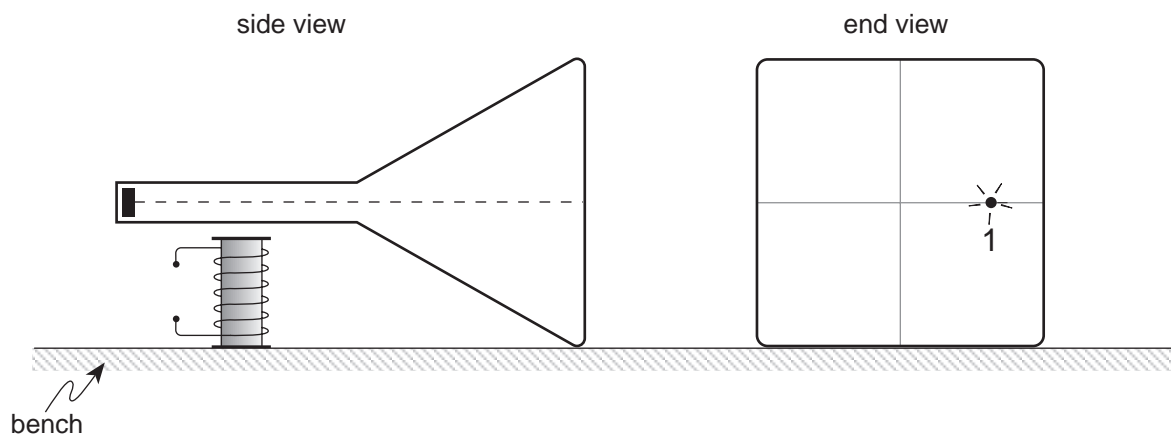

- a) The electrons that make up the beam travel at  $4.7 \times 10^7\text{ m/s}$ . What is the acceleration of the electrons in this field? **(5 marks)**

ANSWER:

a) acceleration of electrons: \_\_\_\_\_

- b) The electron beam is then made to strike the screen at position 2. What two changes were made to the current in the solenoid? State the effect on the electron beam produced by each change. **(4 marks)**

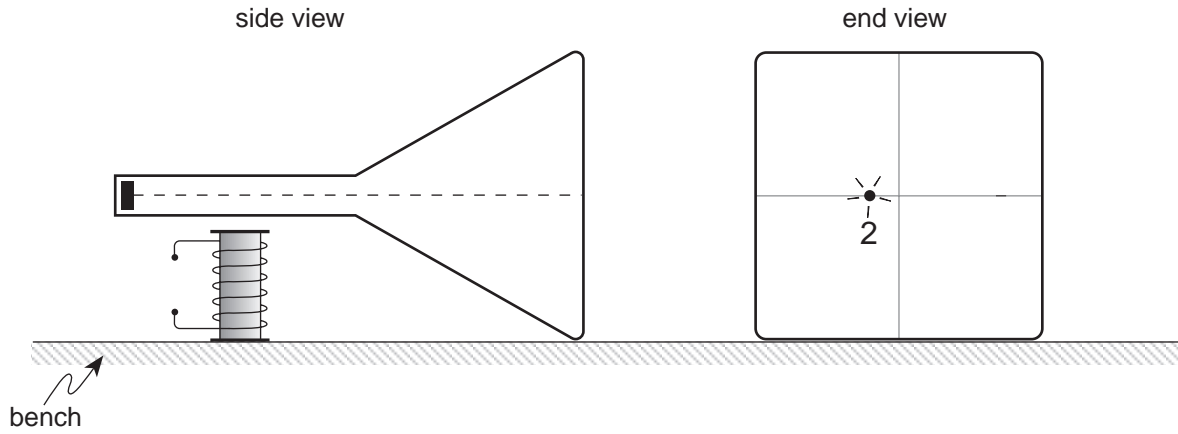

Change in Current	Effect
i)	
ii)	

8. In an experiment, protons are accelerated to different velocities and then subjected to a constant perpendicular magnetic field. The radii of the paths of the protons are measured against their velocities. The data is shown below.

RADIUS (m)	0.061	0.095	0.132	0.149	0.174
VELOCITY ( $\times 10^6$ m/s)	0.44	0.76	0.98	1.16	1.31

- a) Plot the data on the graph below and draw the best fit straight line.

**(2 marks)**

**Graph of Radius vs Velocity**

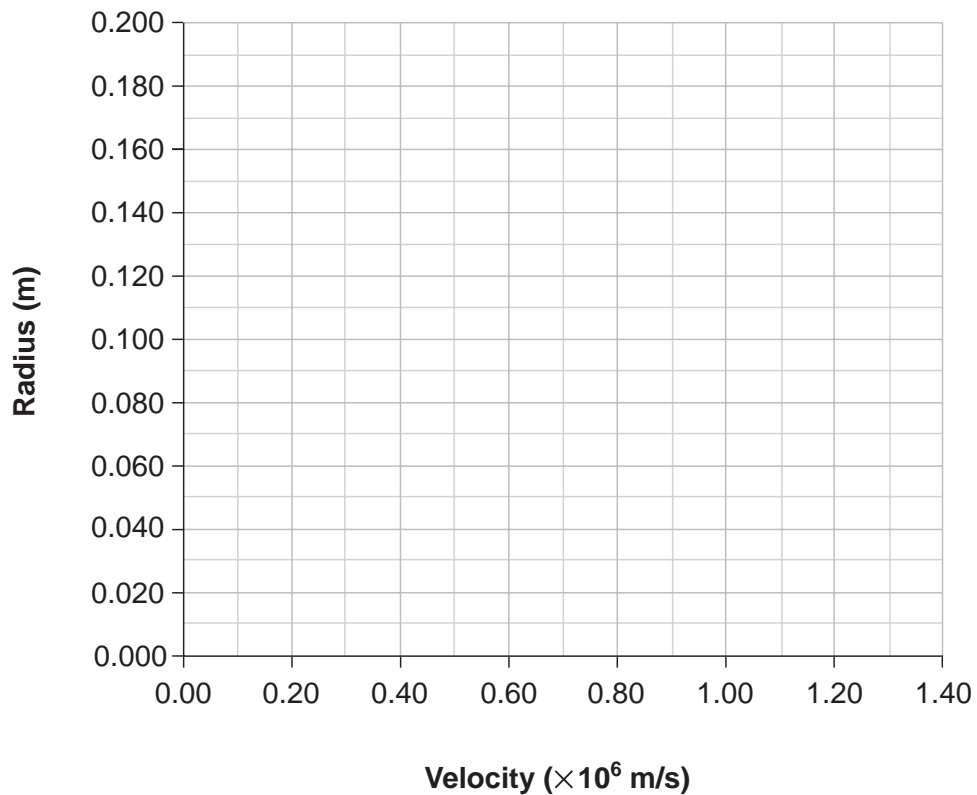

b) Determine the slope of the line. (Include units.)

**(2 marks)**

c) Electrons replace the protons in the above experiment. The slope of the line will now be:

**(1 mark)**

- larger than before
- same as before
- smaller than before

9. An object is dropped from a significant height above the surface of the Moon. It is observed to fall with increasing acceleration. Using principles of physics, give an explanation for this observation.

**(4 marks)**

---

---

---

---

---

---

---

**END OF EXAMINATION**

## TABLE OF CONSTANTS

Gravitational constant.....	$G = 6.67 \times 10^{-11} \text{ N} \cdot \text{m}^2/\text{kg}^2$
Acceleration due to gravity at the surface of Earth (for the purposes of this examination).....	$g = 9.80 \text{ m/s}^2$
<b>Earth</b>	
radius .....	$= 6.38 \times 10^6 \text{ m}$
radius of orbit about Sun .....	$= 1.50 \times 10^{11} \text{ m}$
period of rotation .....	$= 8.61 \times 10^4 \text{ s}$
period of revolution about Sun .....	$= 3.16 \times 10^7 \text{ s}$
mass .....	$= 5.98 \times 10^{24} \text{ kg}$
<b>Moon</b>	
radius .....	$= 1.74 \times 10^6 \text{ m}$
radius of orbit about Earth.....	$= 3.84 \times 10^8 \text{ m}$
period of rotation .....	$= 2.36 \times 10^6 \text{ s}$
period of revolution about Earth.....	$= 2.36 \times 10^6 \text{ s}$
mass .....	$= 7.35 \times 10^{22} \text{ kg}$
<b>Sun</b>	
mass .....	$= 1.98 \times 10^{30} \text{ kg}$
Constant in Coulomb's Law.....	$k = 9.00 \times 10^9 \text{ N} \cdot \text{m}^2/\text{C}^2$
Elementary charge .....	$e = 1.60 \times 10^{-19} \text{ C}$
Mass of electron.....	$m_e = 9.11 \times 10^{-31} \text{ kg}$
Mass of proton.....	$m_p = 1.67 \times 10^{-27} \text{ kg}$
Mass of neutron.....	$m_n = 1.68 \times 10^{-27} \text{ kg}$
Permeability of free space .....	$\mu_o = 4\pi \times 10^{-7} \text{ T} \cdot \text{m/A}$
Speed of light .....	$c = 3.00 \times 10^8 \text{ m/s}$

**You may detach this page for convenient reference.  
Exercise care when tearing along perforations.**

# MATHEMATICAL EQUATIONS

## For Right-angled Triangles:

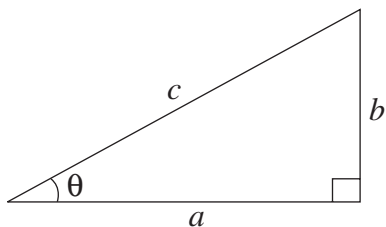

$$a^2 + b^2 = c^2$$

$$\sin \theta = \frac{b}{c} \quad \cos \theta = \frac{a}{c} \quad \tan \theta = \frac{b}{a}$$

$$\text{area} = \frac{1}{2} ab$$

## For All Triangles:

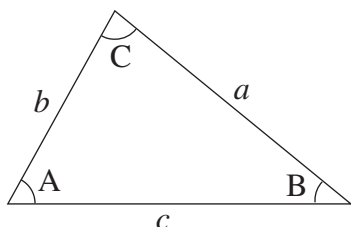

$$\text{area} = \frac{1}{2} \text{base} \times \text{height}$$

$$\sin 2A = 2 \sin A \cos A$$

$$\text{Sine Law: } \frac{\sin A}{a} = \frac{\sin B}{b} = \frac{\sin C}{c}$$

$$\text{Cosine Law: } c^2 = a^2 + b^2 - 2ab \cos C$$

## Circle:

$$\text{Circumference} = 2\pi r$$

$$\text{Area} = \pi r^2$$

## Sphere:

$$\text{Surface area} = 4\pi r^2$$

$$\text{Volume} = \frac{4}{3}\pi r^3$$

## Quadratic Equation:

$$\text{If } ax^2 + bx + c = 0, \text{ then } x = \frac{-b \pm \sqrt{b^2 - 4ac}}{2a}$$



**Vector Kinematics in Two Dimensions:**

$$v = v_0 + at \qquad \bar{v} = \frac{v + v_0}{2}$$

$$v^2 = v_0^2 + 2ad \qquad d = v_0t + \frac{1}{2}at^2$$

**Vector Dynamics:**

$$F_{\text{net}} = ma \qquad F_g = mg$$

$$F_{\text{fr}} = \mu F_N$$

**Work, Energy, and Power:**

$$W = Fd \qquad E_p = mgh$$

$$E_k = \frac{1}{2}mv^2 \qquad P = \frac{W}{t}$$

**Momentum:**

$$p = mv \qquad \Delta p = F\Delta t$$

**Equilibrium:**

$$\tau = Fd$$

**Circular Motion:**

$$a_c = \frac{v^2}{r} = \frac{4\pi^2 r}{T^2}$$

**Gravitation:**

$$F = G \frac{m_1 m_2}{r^2} \qquad E_p = -G \frac{m_1 m_2}{r}$$

**You may detach this page for convenient reference.  
Exercise care when tearing along perforations.**

### Electrostatics:

$$F = k \frac{Q_1 Q_2}{r^2} \quad E = \frac{F}{Q}$$

$$\Delta V = \frac{\Delta E_p}{Q} \quad E = \frac{\Delta V}{d}$$

$$E_p = k \frac{Q_1 Q_2}{r} \quad V = \frac{kQ}{r}$$

### Electric Circuits:

$$I = \frac{Q}{t} \quad V = IR$$

$$V_{\text{terminal}} = \mathcal{E} \pm Ir \quad P = IV$$

### Electromagnetism:

$$F = BIl \quad F = QvB$$

$$B = \mu_0 nI = \mu_0 \frac{N}{l} I \quad \mathcal{E} = Blv$$

$$\Phi = BA \quad \mathcal{E} = -N \frac{\Delta \Phi}{\Delta t}$$

$$V_{\text{back}} = \mathcal{E} - Ir$$

$$\frac{V_s}{V_p} = \frac{N_s}{N_p} = \frac{I_p}{I_s}$$

**ROUGH WORK FOR MULTIPLE-CHOICE**

**You may detach this page for convenient reference.  
Exercise care when tearing along perforations.**

# ROUGH WORK FOR MULTIPLE-CHOICE