

JANUARY 1996

## PROVINCIAL EXAMINATION

---

MINISTRY OF EDUCATION

# CHEMISTRY 12

### GENERAL INSTRUCTIONS

1. Insert the stickers with your Student I.D. Number (PEN) in the allotted spaces above. **Under no circumstance is your name or identification, other than your Student I.D. Number, to appear on this paper.**
2. Take the separate Answer Sheet and follow the directions on its front page.
3. Be sure you have an HB pencil and an eraser for completing your Answer Sheet. Follow the directions on the Answer Sheet when answering multiple-choice questions.
4. For each of the written-response questions, write your answer in the space provided.
5. When instructed to open this booklet, **check the numbering of the pages** to ensure that they are numbered in sequence from page one to the last page, which is identified by

**END OF EXAMINATION**.

6. At the end of the examination, place your Answer Sheet inside the front cover of this booklet and return the booklet and your Answer Sheet to the supervisor.

**THIS PAGE INTENTIONALLY BLANK**

**FOR OFFICE USE ONLY**

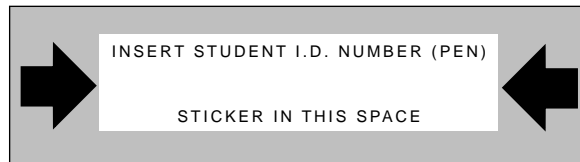

\_\_\_\_\_ - \_\_\_\_\_

**CHEMISTRY 12 JANUARY 1996 PROVINCIAL**

**Course Code = CH Examination Type = P**

1. \_\_\_\_\_  
(2)

2. \_\_\_\_\_  
(2)

3. \_\_\_\_\_  
(4)

4. \_\_\_\_\_  
(1)

5. \_\_\_\_\_  
(3)

6. \_\_\_\_\_  
(3)

7. \_\_\_\_\_  
(2)

8. \_\_\_\_\_  
(3)

9. \_\_\_\_\_  
(5)

10. \_\_\_\_\_  
(4)

11. \_\_\_\_\_  
(3)

**THIS PAGE INTENTIONALLY BLANK**

## CHEMISTRY 12 PROVINCIAL EXAMINATION

	Value	Suggested Time
1. This examination consists of <b>two</b> parts:		
PART A: 48 multiple-choice questions	48	70
PART B: 11 written-response questions	32	50
	<b>Total: 80 marks</b>	<b>120 minutes</b>

2. The following tables can be found in the separate **Data Booklet**.

- Periodic Table of the Elements
- Atomic Masses of the Elements
- Names, Formulae, and Charges of Some Common Ions
- Solubility of Common Compounds in Water
- Solubility Product Constants at 25° C
- Relative Strengths of Brønsted-Lowry Acids and Bases
- Acid-Base Indicators
- Standard Reduction Potentials of Half-cells

No other reference materials or tables are allowed.

3. An approved scientific calculator is essential for the examination. The calculator must be a hand-held device designed **only** for mathematical computations such as logarithmic and trigonometric functions. It **can be** programmable, but **must not** contain any graphing capabilities. You **must not** bring into the examination room any devices to support calculators such as manuals, printed or electronic cards, printers, memory expansion chips or cards, or keyboards.
4. You have **two hours** to complete this examination.

**THIS PAGE INTENTIONALLY BLANK**

## PART A: MULTIPLE-CHOICE

Value: 48 marks

Suggested Time: 70 minutes

**INSTRUCTIONS:** For each question, select the **best** answer and record your choice on the Answer Sheet provided. Using an HB pencil, completely fill in the circle that has the letter corresponding to your answer.

1. Consider the following reaction:

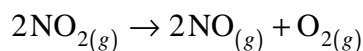

Under certain conditions, the rate of decomposition of  $\text{NO}_2$  is  $3.2 \times 10^{-3}$  mol/s. The rate of formation of  $\text{O}_2$  is

- A.  $1.6 \times 10^{-3}$  mol/s
  - B.  $3.2 \times 10^{-3}$  mol/s
  - C.  $4.8 \times 10^{-3}$  mol/s
  - D.  $6.4 \times 10^{-3}$  mol/s
2. Consider the following reactions:

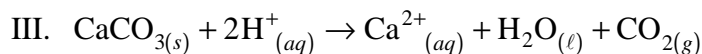
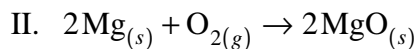
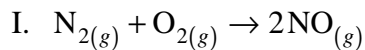

Increasing the surface area will increase the reaction rate in

- A. II only
  - B. I and III only
  - C. II and III only
  - D. I, II and III
3. A catalyst increases the rate of a reaction by
- A. increasing the concentration of the reactant(s).
  - B. decreasing the concentration of the reactant(s).
  - C. increasing the activation energy of the overall reaction.
  - D. decreasing the activation energy of the overall reaction.

4. Consider the following potential energy diagram that represents two different reactions.

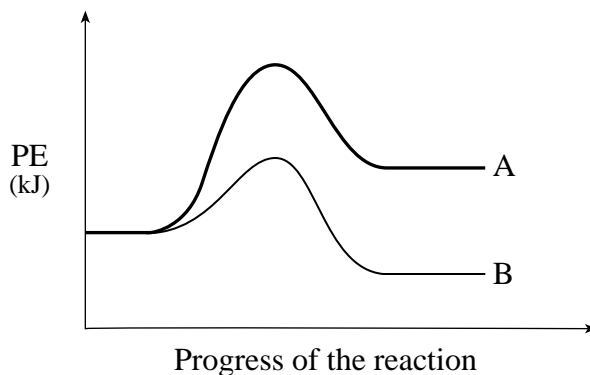

Which of the following statements is correct?

- A. Reactions A and B are both exothermic.
- B. Reactions A and B are both endothermic.
- C. Reaction A is exothermic and reaction B is endothermic.
- D. Reaction A is endothermic and reaction B is exothermic.

5. Consider the following potential energy diagram:

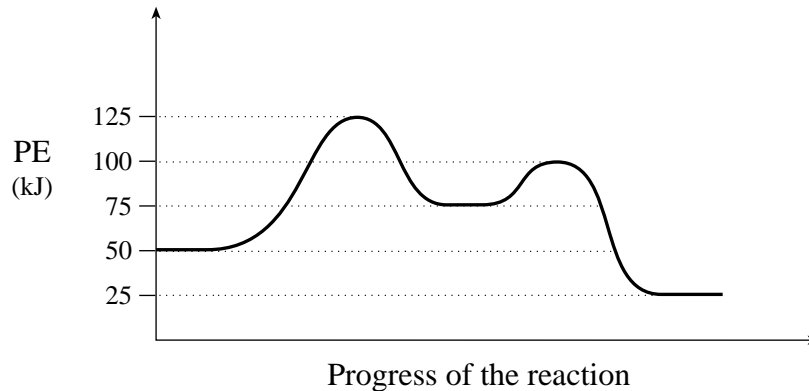

The activation energy for the **forward** reaction is

- A. 25 kJ
- B. 50 kJ
- C. 75 kJ
- D. 125 kJ



6. Consider the following reaction mechanism:

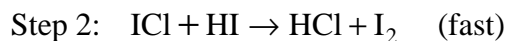
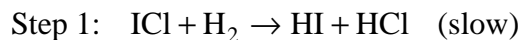

The species HCl is a

- A. product.
  - B. catalyst.
  - C. reactant.
  - D. reaction intermediate.
7. In which of the following does the entropy decrease?

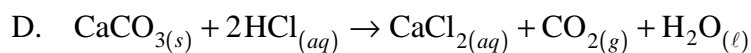
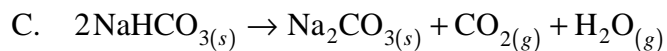
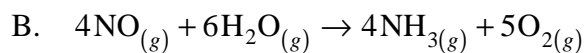
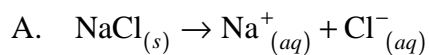

8. Consider the following equilibrium:

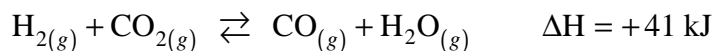

The temperature of the above equilibrium system is increased while kept at a constant volume. A new state of equilibrium is established in which there is

- A. an increase in [CO] and a decrease in  $K_{eq}$
- B. an increase in [CO] and an increase in  $K_{eq}$
- C. an increase in [CO<sub>2</sub>] and a decrease in  $K_{eq}$
- D. an increase in [CO<sub>2</sub>] and an increase in  $K_{eq}$

9. Consider the following equilibrium:

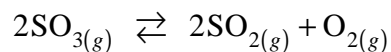

The volume of the system is decreased at a constant temperature. A new state of equilibrium is established by a shift of the original equilibrium to the

- A. left and  $[\text{SO}_3]$  increases.
- B. right and  $[\text{SO}_3]$  decreases.
- C. left and  $[\text{SO}_3]$  remains unchanged.
- D. right and  $[\text{SO}_3]$  remains unchanged.

10. Consider the following equilibrium:

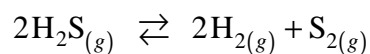

At equilibrium,  $[\text{H}_2\text{S}] = 0.50 \text{ mol/L}$ ,  $[\text{H}_2] = 0.10 \text{ mol/L}$  and  $[\text{S}_2] = 0.40 \text{ mol/L}$ .  
The value of  $K_{eq}$  is calculated using the ratio

- A.  $\frac{(0.10)(0.40)}{(0.50)}$
- B.  $\frac{(0.10)^2(0.40)}{(0.50)^2}$
- C.  $\frac{(0.50)}{(0.10)(0.50)}$
- D.  $\frac{(0.50)^2}{(0.10)^2(0.40)}$

11. Consider the following equilibrium:

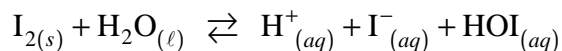

The equilibrium constant expression for the above system is

A.  $K_{eq} = [\text{H}^+][\text{I}^-]$

B.  $K_{eq} = [\text{H}^+][\text{I}^-][\text{HOI}]$

C.  $K_{eq} = \frac{[\text{H}^+][\text{I}^-][\text{HOI}]}{[\text{I}_2][\text{H}_2\text{O}]}$

D.  $K_{eq} = \frac{[\text{H}^+][\text{I}^-][\text{HOI}]}{[\text{H}_2\text{O}]}$

12. In an exothermic equilibrium reaction involving only gases, the value of  $K_{eq}$  can be **decreased** by

- A. adding some reactant gas.
- B. removing some reactant gas.
- C. increasing the temperature.
- D. decreasing the temperature.

13. Consider the following equilibrium:



At equilibrium,  $[\text{NOCl}] = 1.60 \text{ mol/L}$  and  $[\text{NO}] = 0.80 \text{ mol/L}$ . The  $[\text{Cl}_2]$  is

- A. 0.17 mol/L
- B. 0.27 mol/L
- C. 0.33 mol/L
- D. 3.0 mol/L

14. The equation that represents the equilibrium in a saturated solution of  $\text{Fe}_2(\text{SO}_4)_3$  is
- A.  $\text{Fe}_2(\text{SO}_4)_{3(s)} \rightleftharpoons 3\text{Fe}^{2+}_{(aq)} + 2\text{SO}_4^{3-}_{(aq)}$
  - B.  $\text{Fe}_2(\text{SO}_4)_{3(s)} \rightleftharpoons 2\text{Fe}^{2+}_{(aq)} + 3\text{SO}_4^{3-}_{(aq)}$
  - C.  $\text{Fe}_2(\text{SO}_4)_{3(s)} \rightleftharpoons 3\text{Fe}^{3+}_{(aq)} + 2\text{SO}_4^{2-}_{(aq)}$
  - D.  $\text{Fe}_2(\text{SO}_4)_{3(s)} \rightleftharpoons 2\text{Fe}^{3+}_{(aq)} + 3\text{SO}_4^{2-}_{(aq)}$
15. A solution of  $\text{AgNO}_3$  is slowly added to a mixture containing  $0.10 \text{ M } \text{I}^-$ ,  $\text{Cl}^-$ ,  $\text{Br}^-$  and  $\text{IO}_3^-$ . The precipitate which forms first is
- A.  $\text{AgI}$
  - B.  $\text{AgCl}$
  - C.  $\text{AgBr}$
  - D.  $\text{AgIO}_3$
16. Which of the following ions could be used to separate  $\text{Cl}^-_{(aq)}$  from  $\text{SO}_4^{2-}_{(aq)}$  by precipitation?
- A.  $\text{Ag}^+$
  - B.  $\text{Ca}^{2+}$
  - C.  $\text{NH}_4^+$
  - D.  $\text{Pb}^{2+}$
17. Which of the following could be used to precipitate both  $\text{Mg}^{2+}$  and  $\text{Ca}^{2+}$  from hard water?
- A. lithium sulphate
  - B. sodium phosphate
  - C. potassium sulphide
  - D. ammonium chloride
18. The solubility of manganese(II) sulphide is  $1.7 \times 10^{-7} \text{ M}$  at  $25^\circ \text{C}$ . The solubility product constant is
- A.  $2.9 \times 10^{-14}$
  - B.  $1.7 \times 10^{-7}$
  - C.  $3.4 \times 10^{-7}$
  - D.  $4.1 \times 10^{-4}$

19. What is the maximum  $[\text{Ag}^+]$  that can exist in 0.20 M  $\text{NaBrO}_3$  ?

- A.  $1.1 \times 10^{-5}$  M
- B.  $5.3 \times 10^{-5}$  M
- C.  $2.6 \times 10^{-4}$  M
- D.  $7.3 \times 10^{-3}$  M

20. Consider the following equilibrium:

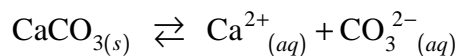

Which of the following reagents, when added to the equilibrium system, would cause more  $\text{CaCO}_3$  to dissolve?

- A.  $\text{KNO}_{3(s)}$
- B.  $\text{CaCO}_{3(s)}$
- C.  $\text{H}_2\text{C}_2\text{O}_{4(s)}$
- D.  $\text{Na}_2\text{CO}_{3(s)}$

21. The conjugate base of  $\text{H}_2\text{BO}_3^-$  is

- A.  $\text{BO}_3^{3-}$
- B.  $\text{H}_3\text{BO}_3$
- C.  $\text{HBO}_3^{2-}$
- D.  $\text{H}_3\text{BO}_3^-$

22. Which of the following is the **weakest** acid?

- A.  $\text{HClO}$
- B.  $\text{HClO}_2$
- C.  $\text{HClO}_3$
- D.  $\text{HClO}_4$

23. Consider the following equilibrium for the indicator bromthymol blue:

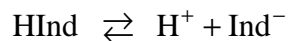

A solution of bromthymol blue is yellow. What should a student do to change the colour of the solution to blue?

- A. Add a base to shift the equilibrium left.
- B. Add an acid to shift the equilibrium left.
- C. Add a base to shift the equilibrium right.
- D. Add an acid to shift the equilibrium right.

24. Which of the following is amphiprotic in water?

- A.  $\text{SO}_2$
- B.  $\text{SO}_3^{2-}$
- C.  $\text{HSO}_3^-$
- D.  $\text{H}_2\text{SO}_3$

25. Water acts as a base when it reacts with

- A.  $\text{CN}^-$
- B.  $\text{NH}_3$
- C.  $\text{NO}_2^-$
- D.  $\text{NH}_4^+$

26. The  $[\text{OH}^-]$  in 0.050 M  $\text{HNO}_3$  at  $25^\circ\text{C}$  is

- A.  $5.0 \times 10^{-16} \text{ M}$
- B.  $1.0 \times 10^{-14} \text{ M}$
- C.  $2.0 \times 10^{-13} \text{ M}$
- D.  $5.0 \times 10^{-2} \text{ M}$

27. Consider the following equilibrium constant expression:

$$K = \frac{[\text{H}_2\text{S}][\text{OH}^-]}{[\text{HS}^-]}$$

This expression represents the

- A.  $K_b$  for  $\text{H}_2\text{S}$
  - B.  $K_a$  for  $\text{H}_2\text{S}$
  - C.  $K_b$  for  $\text{HS}^-$
  - D.  $K_a$  for  $\text{HS}^-$
28. Which of the following 0.10 M solutions will be yellow in the presence of the indicator chlorophenol red?
- A.  $\text{AlCl}_3$
  - B.  $\text{CaCl}_2$
  - C.  $\text{K}_2\text{CO}_3$
  - D.  $\text{Na}_3\text{PO}_4$
29. Consider the following data:

SOLUTION	INITIAL pH	FINAL pH
1	1.0	4.0
2	2.0	6.0
3	6.0	3.0
4	9.0	3.0

In which solution has the  $[\text{H}_3\text{O}^+]$  increased 1000 times ?

- A. 1
- B. 2
- C. 3
- D. 4

30. The pOH of an aqueous solution is equal to
- A.  $14 + \text{pH}$
  - B.  $\text{pK}_w - \text{pH}$
  - C.  $-\log \text{pK}_w$
  - D.  $-\log[\text{H}_3\text{O}^+]$
31. The reaction of a strong acid with a strong base produces
- A. a salt and water.
  - B. a base and an acid.
  - C. a metallic oxide and water.
  - D. a non-metallic oxide and water.
32. The stoichiometric point of a titration is reached when 35.50 mL 0.40 M HBr is added to a 25.00 mL sample of LiOH. The original [LiOH] is
- A. 0.014 M
  - B. 0.024 M
  - C. 0.28 M
  - D. 0.57 M
33. What is the pH of a solution prepared by adding 0.50 mol KOH to 1.0 L of 0.30 M  $\text{HNO}_3$ ?
- A. 0.20
  - B. 0.70
  - C. 13.30
  - D. 13.80
34. A **basic** buffer solution can be prepared by mixing equal numbers of moles of
- A.  $\text{NH}_4\text{Cl}$  and HCl
  - B. NaCl and NaOH
  - C.  $\text{Na}_2\text{CO}_3$  and  $\text{NaHCO}_3$
  - D.  $\text{NaCH}_3\text{COO}$  and  $\text{CH}_3\text{COOH}$
35. The pH range of 'acid rain' is often
- A. 3 to 6
  - B. 6 to 8
  - C. 7 to 9
  - D. 10 to 12



36. Identify the indicator that is blue in a solution when  $[\text{H}_3\text{O}^+] = 2.5 \times 10^{-6}$ .
- A. thymol blue
  - B. thymolphthalein
  - C. bromthymol blue
  - D. bromcresol green

37. Consider the following redox reaction:

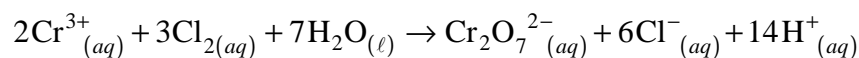

The species which loses electrons is

- A.  $\text{Cl}_2$
  - B.  $\text{Cr}^{3+}$
  - C.  $\text{H}_2\text{O}$
  - D.  $\text{Cr}_2\text{O}_7^{2-}$
38. The species which gains electrons in a redox reaction
- A. loses mass.
  - B. is oxidized.
  - C. is the oxidizing agent.
  - D. increases in oxidation number.
39. The oxidation number of carbon in  $\text{CaC}_2\text{O}_4$  is
- A. +2
  - B. +3
  - C. +4
  - D. +6
40. When  $\text{MnO}_4^-$  reacts to form  $\text{Mn}^{2+}$ , the manganese in  $\text{MnO}_4^-$  is
- A. reduced as its oxidation number increases.
  - B. reduced as its oxidation number decreases.
  - C. oxidized as its oxidation number increases.
  - D. oxidized as its oxidation number decreases.

**OVER**

Use the following diagram to answer questions 41 to 43.

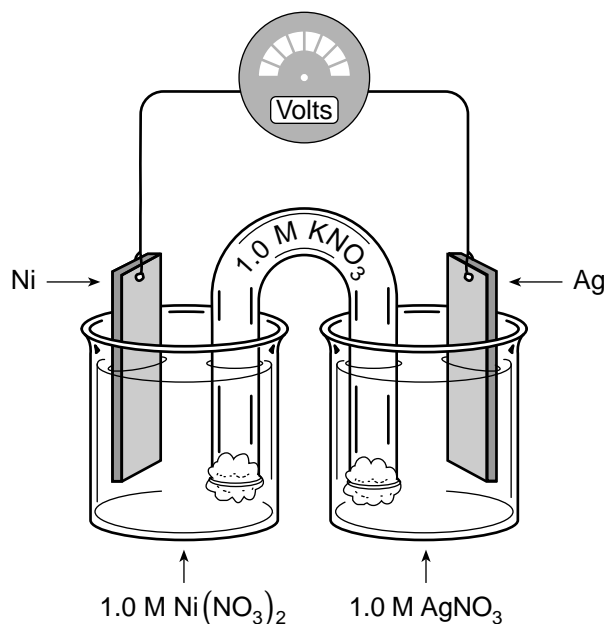

41. The balanced equation for the overall reaction is

- A.  $\text{Ni}^+_{(aq)} + \text{Ag}_{(s)} \rightarrow \text{Ag}^+_{(aq)} + \text{Ni}_{(s)}$
- B.  $\text{Ni}_{(s)} + \text{Ag}^+_{(aq)} \rightarrow \text{Ag}_{(s)} + \text{Ni}^+_{(aq)}$
- C.  $\text{Ni}^{2+}_{(aq)} + 2\text{Ag}_{(s)} \rightarrow 2\text{Ag}^+_{(aq)} + \text{Ni}_{(s)}$
- D.  $\text{Ni}_{(s)} + 2\text{Ag}^+_{(aq)} \rightarrow 2\text{Ag}_{(s)} + \text{Ni}^{2+}_{(aq)}$

42. This redox reaction occurs because

- A.  $\text{Ag}_{(s)}$  is a stronger oxidizing agent than  $\text{Ni}_{(s)}$
- B.  $\text{Ag}_{(s)}$  is a weaker reducing agent than  $\text{Ni}_{(s)}$
- C.  $\text{Ag}^+_{(aq)}$  is a stronger reducing agent than  $\text{Ni}^{2+}_{(aq)}$
- D.  $\text{Ag}^+_{(aq)}$  is a weaker oxidizing agent than  $\text{Ni}^{2+}_{(aq)}$

43. The initial cell voltage at 25°C is

- A. -1.06 V
- B. -0.54 V
- C. +0.54 V
- D. +1.06 V

44. In the electrolysis of molten zinc chloride, the half-reaction at the anode is

- A.  $\text{Cl}_2 + 2\text{e}^- \rightarrow 2\text{Cl}^-$
- B.  $2\text{Cl}^- \rightarrow \text{Cl}_2 + 2\text{e}^-$
- C.  $\text{Zn}^{2+} + 2\text{e}^- \rightarrow \text{Zn}$
- D.  $\text{Zn} \rightarrow \text{Zn}^{2+} + 2\text{e}^-$

45. Corrosion of iron can be prevented by attaching a piece of

- A. Mn
- B. Cu
- C. Pb
- D. Sn

46. To plate a nickel coin with copper,

- A. the nickel coin must be the cathode.
- B. the cathode must be made of copper.
- C. the electrons must flow to the anode.
- D. the solution must contain nickel ions.

47. Consider the following redox reaction:

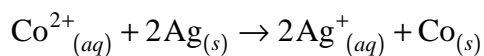

The reaction is

- A. spontaneous and  $E^\circ$  is positive.
- B. spontaneous and  $E^\circ$  is negative.
- C. non-spontaneous and  $E^\circ$  is positive.
- D. non-spontaneous and  $E^\circ$  is negative.

48. Which of the following ions can be reduced from an aqueous solution?

- A.  $\text{Ba}^{2+}$
- B.  $\text{Al}^{3+}$
- C.  $\text{Sn}^{2+}$
- D.  $\text{Na}^+$

**This is the end of the multiple-choice section.**  
**Answer the remaining questions directly in this examination booklet.**

**OVER**

## PART B: WRITTEN-RESPONSE

Value: 32 marks

Suggested Time: 50 minutes

**INSTRUCTIONS:** You will be expected to communicate your knowledge and understanding of chemical principles in a clear and logical manner.  
Your steps and assumptions leading to a solution must be written in the spaces below the questions.  
Answers must include units where appropriate and be given to the correct number of significant figures.  
**For questions involving calculation, full marks will NOT be given for providing only an answer.**

1. a) On the graph below, draw the potential energy diagram for an exothermic reaction and label the activation energy. **(1 mark)**



- b) Define the term *activation energy*. **(1 mark)**

---

---

---

Score for  
Question 1:

1.           
(2)

2. Consider the following reaction mechanism:

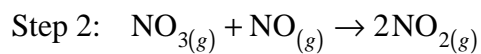
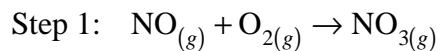

a) Identify a reaction intermediate.

**(1 mark)**

\_\_\_\_\_

b) Write the equation for the overall reaction.

**(1 mark)**

Score for  
Question 2:

2. \_\_\_\_\_  
(2)

3. Consider the following equilibrium:

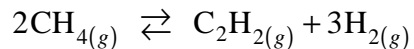

A 0.180 mol sample of  $\text{CH}_4$  is added to an empty 1.00 L container. At equilibrium, the  $[\text{C}_2\text{H}_2]$  is 0.0800 mol/L. Calculate the equilibrium constant. **(4 marks)**

Score for  
Question 3:

3. \_\_\_\_\_  
(4)

**OVER**

4. Consider the following equilibrium:

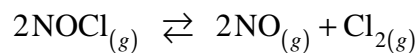

A chemist places 2.00 mol NOCl in a 1.0 L container. Describe the changes in [NOCl] and [Cl<sub>2</sub>] as the system approaches equilibrium. **(1 mark)**

---

---

---

Score for  
Question 4:

4.           
(1)

5. A saturated solution of BaSO<sub>4</sub> is given to patients needing digestive tract x-rays.

a) Write an equation that represents the solubility equilibrium. **(1 mark)**

b) Calculate the [Ba<sup>2+</sup>] present in the saturated solution. **(2 marks)**

Score for  
Question 5:

5.           
(3)

6. Will a precipitate form when 90.0 mL of  $1.00 \times 10^{-2}$  M  $\text{Cu}(\text{NO}_3)_2$  and 10.0 mL of  $1.00 \times 10^{-2}$  M  $\text{NaIO}_3$  are mixed? Explain using appropriate calculations.

**(3 marks)**

Score for  
Question 6:

6.           
(3)

**OVER**

7. Consider the following equilibrium:

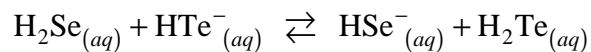

The reactants are favoured in this equilibrium.

a) Identify the stronger acid. \_\_\_\_\_ **(1 mark)**

b) Identify the weaker base. \_\_\_\_\_ **(1 mark)**

Score for  
Question 7:

7. \_\_\_\_\_  
(2)

8. The hydrogen carbonate ion can act as an acid or a base. Use calculations to determine if a solution containing 0.10 M hydrogen carbonate ion is acidic or basic. **(3 marks)**

Score for  
Question 8:

8. \_\_\_\_\_  
(3)



9. In a titration, 25.00 mL of 0.10 M HCl was neutralized by slowly adding 50.00 mL of 0.10 M NaOH.

a) Sketch the titration curve for the reaction and label:

- the initial pH of the HCl,
- the volume of NaOH required to neutralize the HCl, and
- the pH at the equivalence point.

**(4 marks)**

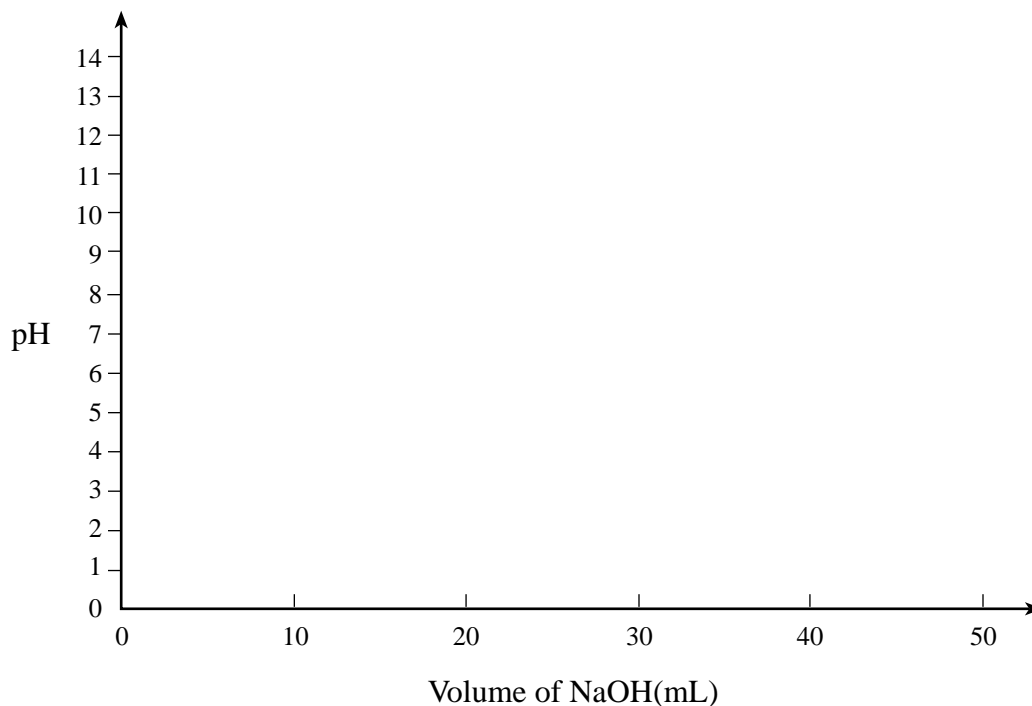

b) Select a suitable indicator for this titration.

**(1 mark)**

Score for  
Question 9:

9.           
(5)

**OVER**

10. Balance the following redox reaction:

(4 marks)

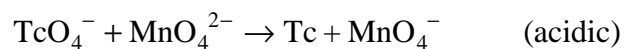

Score for  
Question 10:

10. \_\_\_\_\_  
(4)

11. Consider the following electrochemical cell:

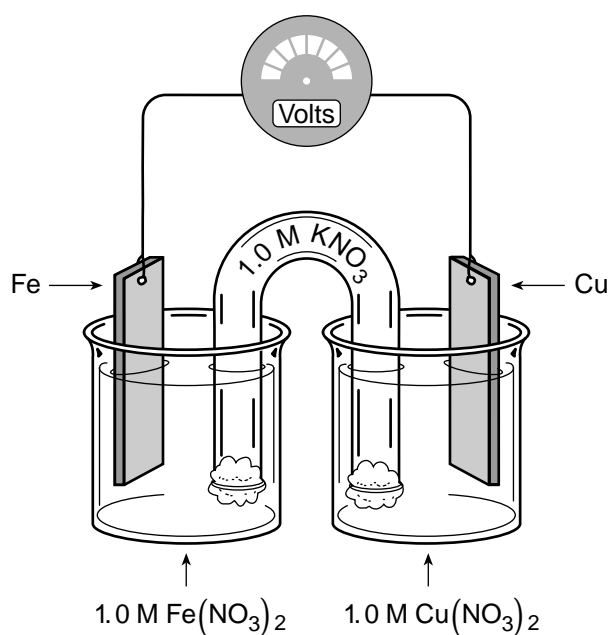

a) Clearly indicate on the diagram above, the direction of electron flow through the wire. (1 mark)

b) Write the equation for the half-reaction taking place at the Fe electrode. (1 mark)

c) What is the initial cell voltage? (1 mark)

Score for  
Question 11:

11. \_\_\_\_\_  
(3)

**END OF EXAMINATION**